

AM · FM · TELEVISION

BROADCAST

NEWS



NEW LIGHTWEIGHT PICKUP and TONE ARM . . . See Pg. 8

MAY-JUNE 1951 — Number 64



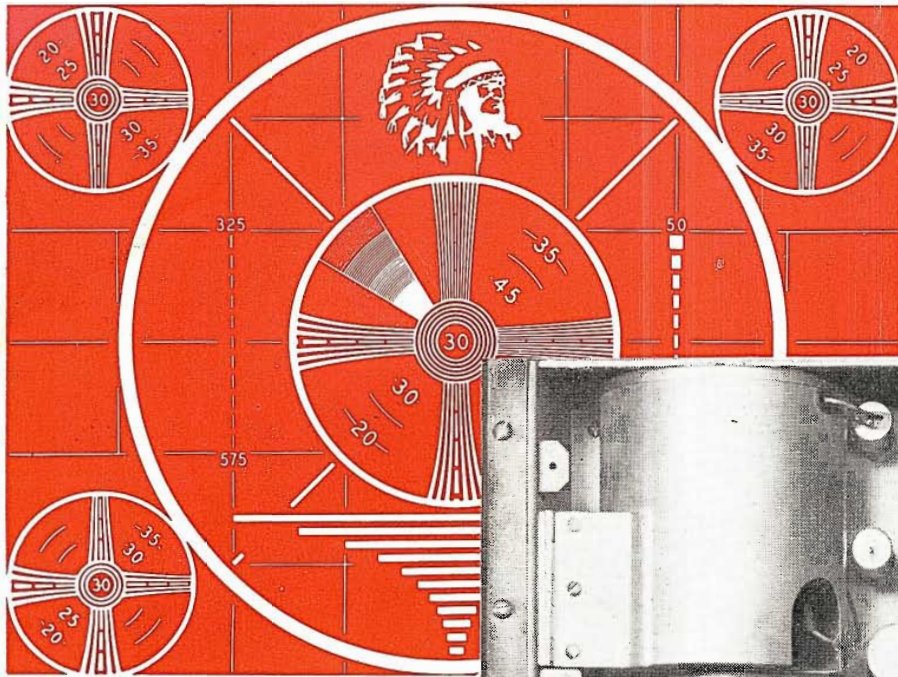

**Video
Monoscope
Camera
TK-1A**

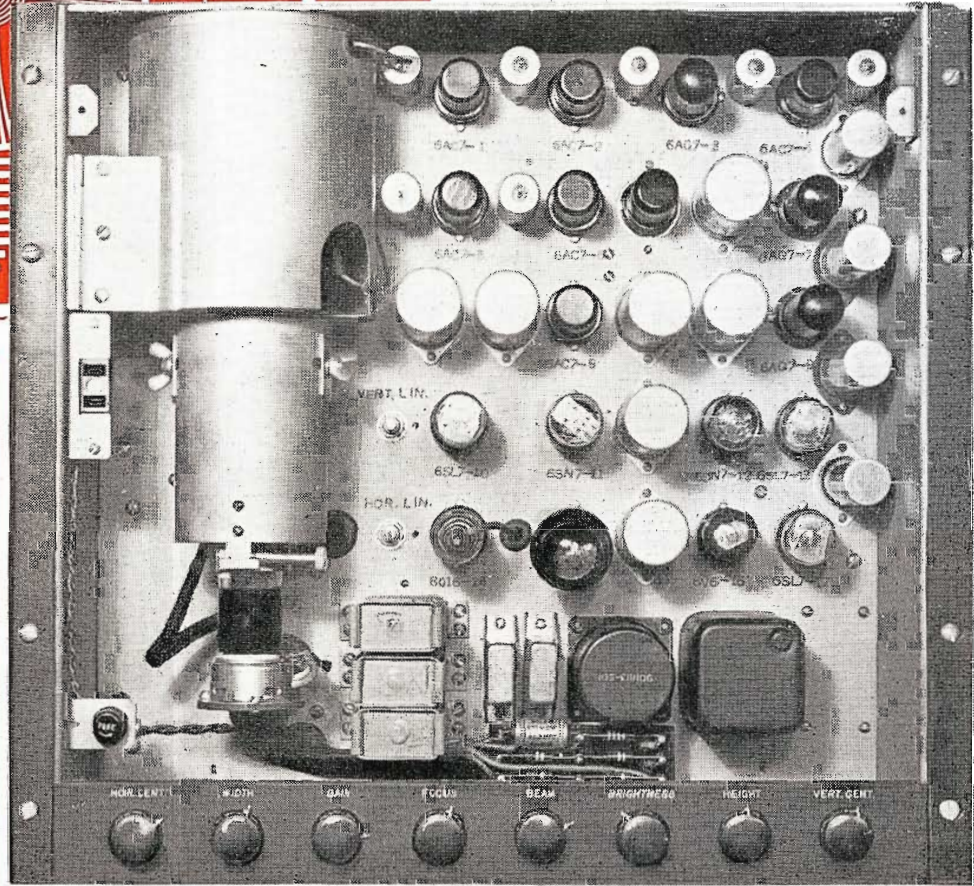

... "patternmaker" for the industry

The test pattern produced by RCA Monoscope Cameras is the standard by which picture quality has been judged since the beginning of electronic television . . . in TV stations . . . in laboratories . . . in TV receiver production.

These are the standard test-pattern cameras used by many TV receiver manufacturers. These are the standard "picture micrometers" used by TV stations to make precision measurements of video transmissions.

Deliberately designed to excel in all things, RCA Monoscope Cameras have earned the extraordinary re-

spect of television men. Evenly lighted patterns as steady as Gibraltar. Resolution as fixed as the cut of a diamond. Operation as reliable as a ship's chronometer.

Type TK-1A pictured here is RCA's newest Monoscope Camera—built to the highest standards known. It can be delivered to you with the familiar monoscope pattern (shown above)—or with a pattern of your own choice.

Ask your RCA Television Equipment Sales Engineer for prices. Mail the coupon for data.



TELEVISION BROADCAST EQUIPMENT
RADIO CORPORATION of AMERICA
ENGINEERING PRODUCTS DEPARTMENT, CAMDEN, N. J.

In Canada: RCA VICTOR Company Limited, Montreal

Radio Corporation of America
Television Broadcast Equipment Section
Dept. 87G, Camden, N. J.

Send me your technical bulletin on the RCA Type TK-1A Monoscope Camera.

Name _____

Company or station _____

Address _____

City _____ State _____

Broadcast News

AM • FM • TELEVISION

Published by the

RADIO CORPORATION OF AMERICA

ENGINEERING PRODUCTS DEPARTMENT . . . CAMDEN, NEW JERSEY

NUMBER 64

MAY-JUNE, 1951

Subscription Rates

In continental U. S. A. - \$4.00 for 12 issues

In other countries - - - \$5.00 for 12 issues

JOHN P. TAYLOR, Editor

W. O. HADLOCK, Managing Editor

M. L. GASKILL, E. B. MAY, Associate Editors

Contents

KGVO, MISSOULA, MONTANA . . .	by A. D. DAHL AND CLARENCE L. TOUW	6
NEW LIGHTWEIGHT PICKUP AND TONE ARM	by L. J. ANDERSON AND C. R. JOHNSON	8
METHOD OF DETERMINING THE CAPABILITIES OF A PICKUP	by H. E. ROYS	15
RADIO PIONEERS DINNER		18
RCA's LARGEST NARTB SHOW FEATURES NEW VHF TV EQUIPMENT	by W. O. HADLOCK	20
THE REQUIREMENTS OF TELEVISION STATION DESIGN (PART IV)	by DR. WALTER J. DUSCHINSKY	28
KGO-TV, SAN FRANCISCO	by THE KGO-TV ENGINEERING STAFF	34
A SOLUTION TO THE MAGNETIC TAPE TIMING PROBLEM	by D. R. ANDREWS	42
PRECISION AM FREQUENCY MONITOR	by R. S. MCKINNEY	48
HAM FORUM	by M. L. GASKILL	51
TELEVISION TRANSMITTER MONITORING	by R. A. BOOT AND I. E. GOLDSTEIN	52
HOW TO ADJUST LIMITING AMPLIFIERS	by W. E. STEWART	55
VIDEO RELAY SWITCHING LAYOUTS	by C. R. MONRO	56
AN EDITING MACHINE FOR MAGNETIC TAPE RECORDING	by D. C. YARNES	66

Copyright 1951
Radio Corporation of America
RCA Victor Division
Camden, N. J.

PRINTED
IN
U. S. A.

OUR COVER illustration for this issue is a closeup showing the new Lightweight Pickup and Tone Arm combination which makes it possible to play all three speeds—45, 33½ plus 78's—and just two simple plug-in heads are used. See complete story on page 8. The color illustration on the cover is reproduced from a 4 x 5 Kodachrome taken by our staff photographer, Rod Allen.

EXPLAINING a publication, in that publication, shouldn't be necessary—and we seldom do. However, BROADCAST NEWS has a number of idiosyncrasies which, although old hat to most of our long-time readers, may be a little confusing to our new readers. And, because we have a lot of new readers right now, maybe we should do a little explaining. The following are a few notes on the subject.

EDITORIAL SLANT of BROADCAST NEWS is plain to those in the broadcast industry, but perhaps mysterious to others. It's simple, really! We want readership among the station managers and station engineers who are, or may be, our customers. So we pitch for it by giving them information they can't find (to any large degree) anywhere else. Cheesecake, cartoons, program talent, day-to-day news—even new engineering development in other branches of electronics—can be found elsewhere. So we avoid these. But if it's material that will help stations planning-wise, equipment-wise, or operating-wise—that's for us. Mostly this means down-to-earth stories on how-to-do-it, or how-the-other-fellow-did-it. And, of course, an occasional pitch for our own new products—for which we hope you will forgive us.

PUBLISHING DATES for BROADCAST NEWS tend to be a little flexible, as all of our old-time readers well know. This is only partly our fault; the rest of the fault lies with our authors, who in most cases are also our readers. They continually promise us stories about their pretty new installations. And we continually believe them when they say they'll have it done by such-and-such a date. They never do, of course. And we sit here waiting to put the next issue to bed. What else can we do? After all they are customers . . . God bless 'em!

Well, anyway, by one stratagem or another, we usually manage to get out an issue about every two months. But, since we are continually slipping back a little we don't always get out six issues a year. In the past it has more often been five. However, our managing editor is straining the proverbial this year—and he just might make it.

For the benefit of our subscribers we would note that you don't lose either way. Subscriptions are taken on the basis of twelve issues. And you get twelve, no matter how many years it takes us to produce them.

VOLUME NUMBERS of BROADCAST NEWS are indicated by just about the simplest possible system. As each issue comes out we assign it the next volume number. Thus each issue is a volume. Volume numbers have no relation to years, or any other date.

BACK ISSUES of BROADCAST NEWS are available as follows: Volumes No. 51, 52, 53, 54, 56, 57, 58, 59, 60, 61, and 63. We will be glad to forward any of these you may need for your file, if you will enclose twenty cents per issue to cover cost of handling and mailing. Please note that we have only a small quantity of some issues and we will have to take care of requests on a first come, first served basis.

NO INDEX of BROADCAST NEWS has been printed as yet. Some issues back we offered to print one, if enough interest was shown by our readers. However, the response was something less than overwhelming. And while we're fairly sure this is just because a lot of you are too lazy to write (after all, a card would do)—nevertheless' we're just a bit hurt by that yawning silence. So-o-o, if you want an index now, you'll have to coax us.

Styled to match your audio

Ideal for **EMERGENCY**

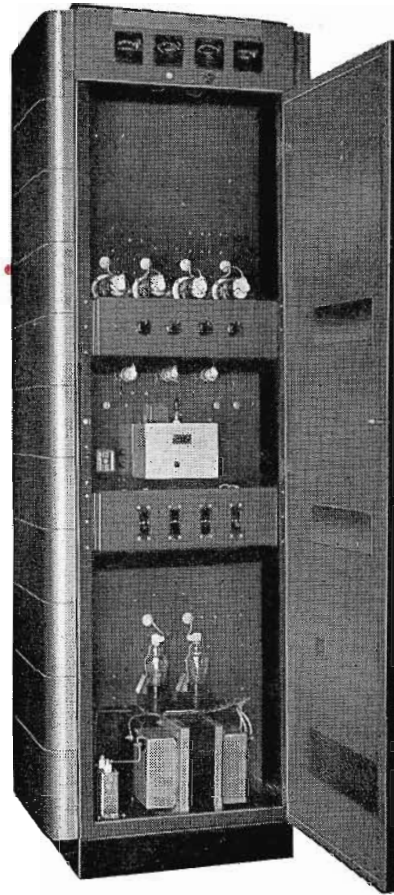
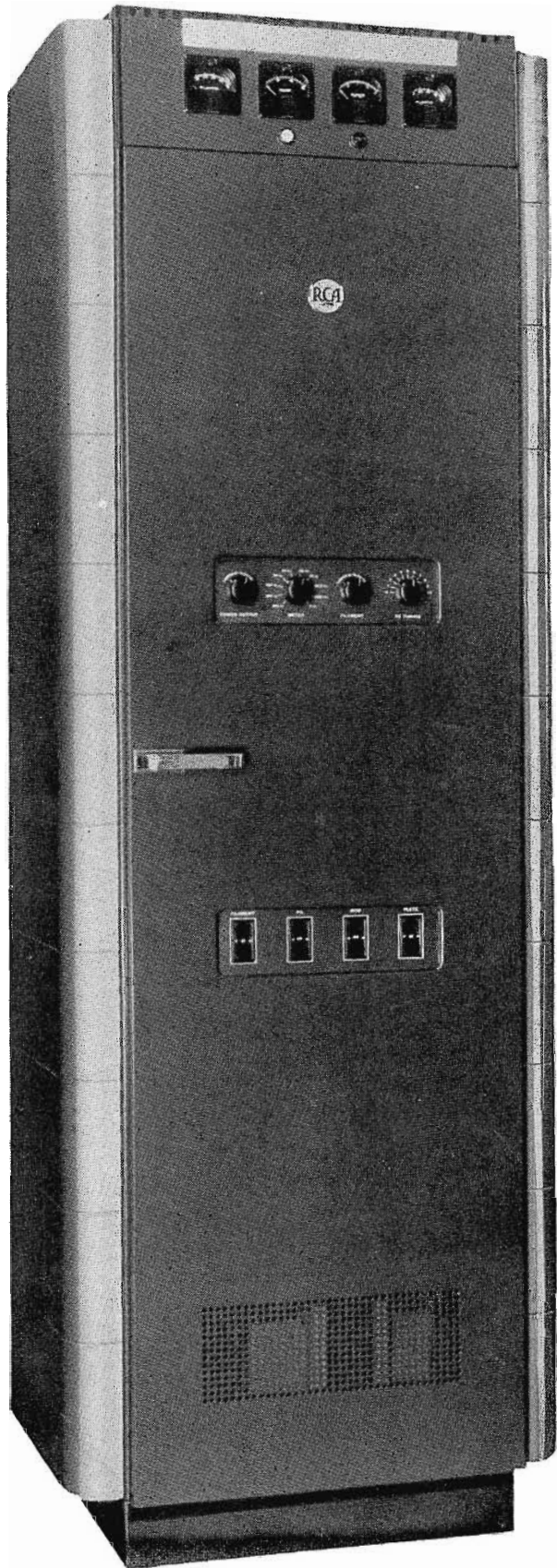

▲
NEAT AND SIMPLE—with everything up
front in easy reach.

◀ **RCA TYPE BTA-250M.** Same size as an audio
rack.



racks...

"on-air"

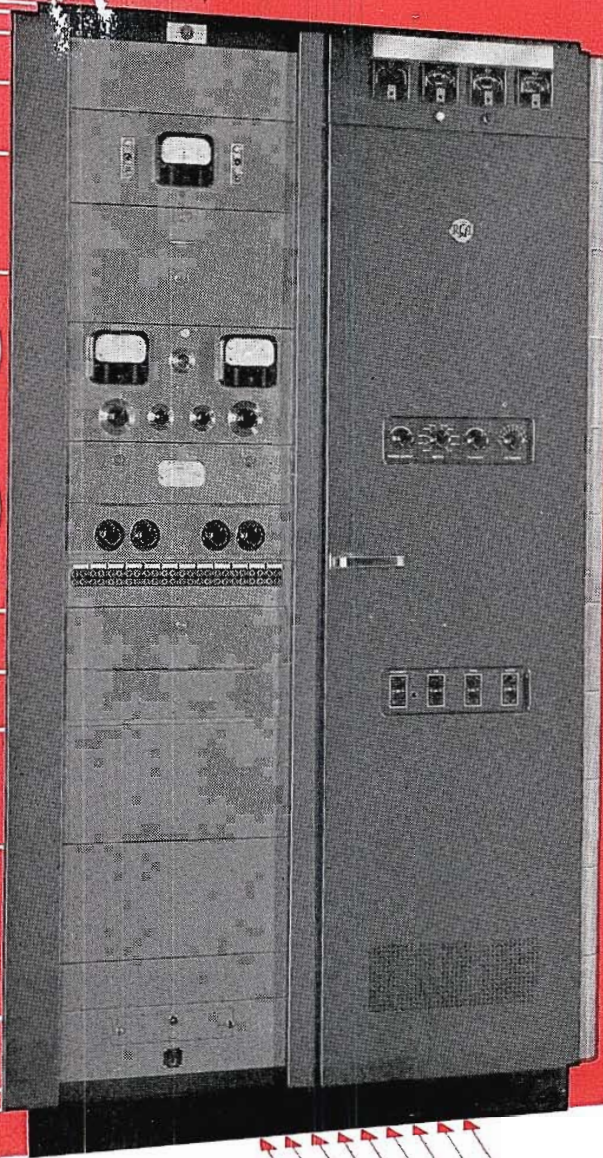

EMERGENCY! Type BTA-250M "on-air" from inside the control room. See how functional styling matches audio racks. Unit on left is the companion audio-and-monitoring unit.

RCA's All-New 250-watt AM Transmitter (Type BTA-250M)

Now you can take advantage of the surest, swiftest method known for staying on the air—regardless of what happens to your main transmitter. The answer—a standby station within the four walls of your control room, including a *complete transmitter and FCC-required monitoring equipment!*

"Feather-quiet" in operation—with no air blowers or A-C contactors—Type BTA-250M is the ideal transmitter for this "security" service. It is a single unit—same size as your audio cabinets—and can be installed in almost any control room set up. Installation is easy, too. *It was planned that way!*

Operation of the BTA-250M is simple. Just one control for tuning, and one for power out-

put. Operating expense is next to nothing. Unmodulated, the transmitter takes only 1000 watts of power to run. Only 10 tubes all told. Only 3 tube types to stock—the RCA-807, 813 and 866A (carefully chosen for their economy, reliability, and availability under present-day conditions).

Here is a 250-watt AM transmitter with the latest electrical and mechanical features. No trick circuits. Compare its performance specifications with those of other AM transmitters. The BTA-250M will outperform any other transmitter in its class!

Be ready for the long pull ahead—with a reliable BTA-250M. It's a major advancement in plant economy for local broadcast stations.

It's the ideal "standby" for master control-room operation in the larger AM station!

Ask your RCA Broadcast Sales Engineer about delivery. Or write Dept. PB-19, RCA Engineering Products, Camden, N. J.

BROADCAST EQUIPMENT
RADIO CORPORATION of AMERICA
ENGINEERING PRODUCTS DEPARTMENT, CAMDEN, N. J.

In Canada: RCA VICTOR Company Limited, Montreal



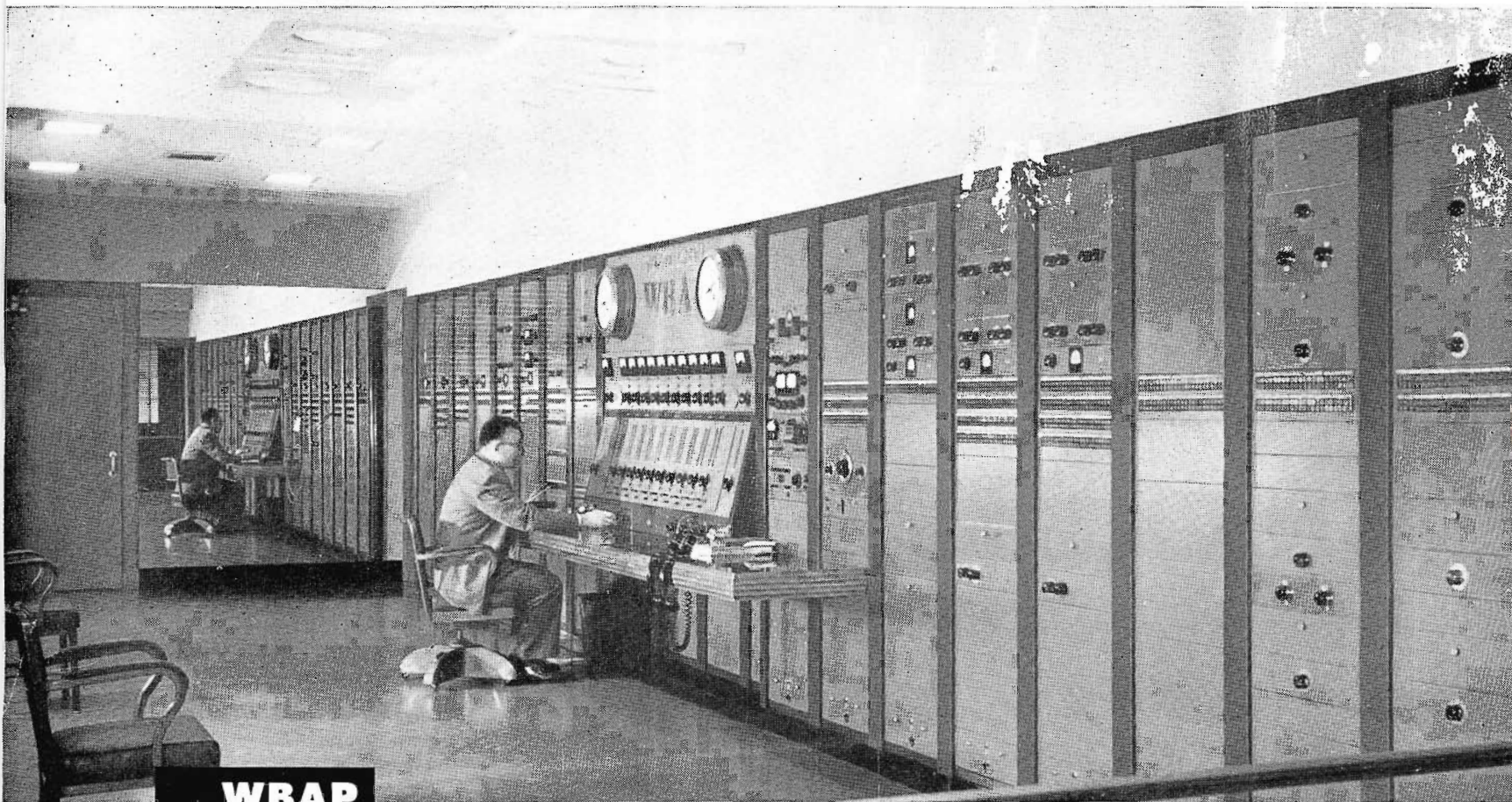

WBAP
FT. WORTH, TEXAS

This master control console, including 16 de luxe audio equipment racks, is part of a modern 6-studio layout—custom-built by RCA. Designed for AM, FM and TV opera-

tion, this "In-Line" design handles 16 studio inputs and feeds 10 output channels—simultaneously, or individually, by a pre-set relay system.

Unlimited audio

Two supervisory positions like this one handle 4 studios, 2 outgoing lines. It includes telephone ringdown, remote switching, talkback, monitoring,

and cueing. This set-up uses existing RCA Consolettes—makes studio and master control functions possible in one location.

WJAC
JOHNSTOWN, PA.



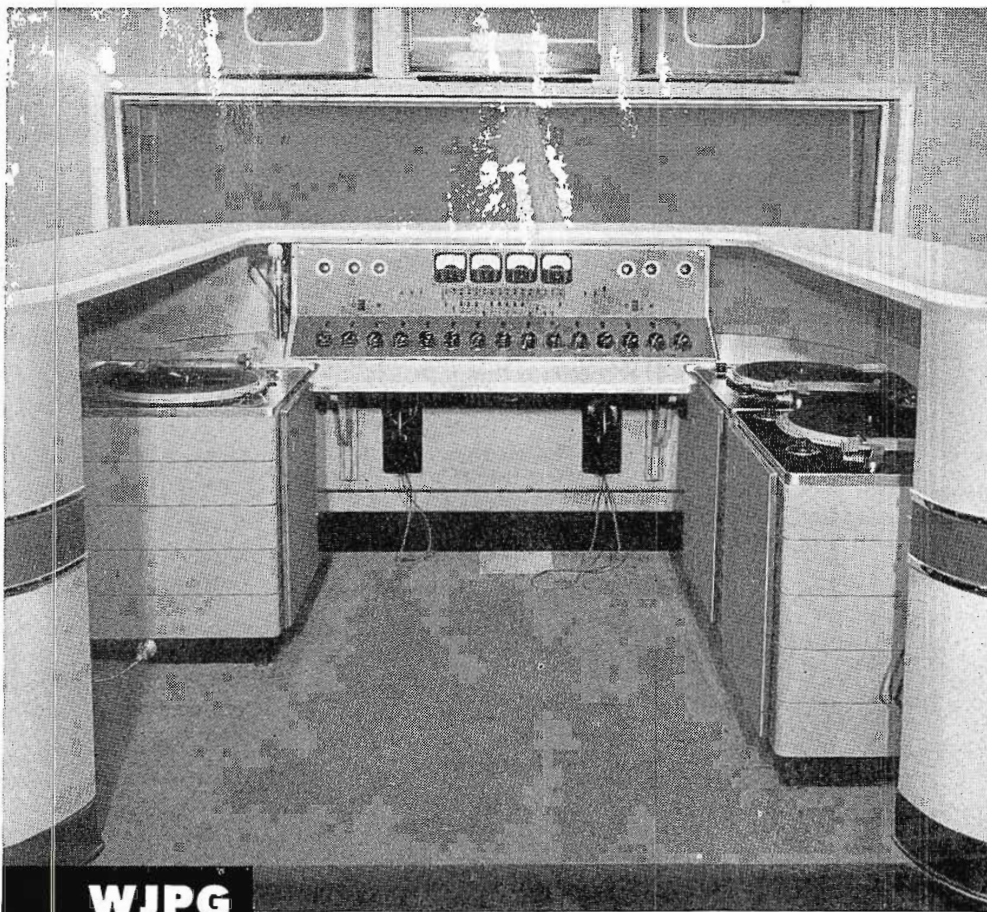

WJPG
GREEN BAY, WISC.

Master control handles 4 studio inputs, 4 output channels, 2 remote inputs, 3 turntable inputs, cueing, monitoring, talkback. This master control and one sub-master handle all program needs.

A few of the many de luxe units available

- Supplementary equipment for Consolettes—switching systems, extra inputs and outputs, jack strips, ringdown, sound-effects filters, and line equalizers
- Master control equipment—to handle any number of studios
- Matched custom wings for consolettes—for studio and master controls
- Custom racks for relay switching
- "One-man" control layouts
- Master control console combinations
- Studio control consoles
- Custom recording—for separate or simultaneous recording
- Custom recording control turrets
- Mobile recording equipment—disc recorders, tape recorders, record playbacks. Everything including the motor vehicle.
- Audio/Video equipment—custom audio, plus video switching, monitors, stabilizing amplifiers.

facilities for

SMALL STATIONS

MEDIUM STATIONS

LARGE STATIONS

RCA fine custom-built studio control systems

..... **W**ith RCA Custom-Built equipment you can extend your audio facilities almost without limit. No matter what size the system, experienced RCA design assures instant, fool-proof switching without program level "pops" or "breaks." Fidelity of sound meets the requirements of the world's severest critics.

Suitable for every AM, FM, and Television station—small, medium, or large—RCA Custom-Built Systems are "individualized" to handle all the studio-control operations anticipated by the

individual plant. Any number of station studios may be provided for . . . any number of remote lines . . . any type of master control . . . all the monitoring, talkback, and cueing facilities needed . . . every conceivable facility for controlling program operations and reproducing high-fidelity sound. True cabinet craftsmanship combines durability with function. Handsome styling and finish enhance station prestige.

Consultation on Custom-Built equipment is provided without obligation to every station—any size. Service includes

detailed layout proposals, diagrams of equipment and facilities, artist's sketches by RCA functional design experts, thorough counsel by RCA's experienced staff of broadcast specialists. Where plans are already down on paper, RCA will be glad to work from these—co-operate closely with your principals.

Your RCA Broadcast Sales Engineer can tell you about this service. For complete information call him, or write Department 7A, RCA Engineering Products, Camden, New Jersey.



AUDIO BROADCAST EQUIPMENT
RADIO CORPORATION of AMERICA
ENGINEERING PRODUCTS DEPARTMENT, CAMDEN, N.J.

In Canada: RCA VICTOR Company Limited, Montreal

KGVO

MISSOULA, MONT.

by
A. D. DAHL
Chief Engineer
and
CLARENCE L. TOUW
Transmitter Supervisor

Several years ago it was decided by Mr. A. J. Mosby, president of Mosby's Incorporated, to put up a new transmitting plant in a more favorable location rather than that of the old site which was mostly gravel and very dry. This more favorable site was found some five miles south of Missoula, Montana. A request for a construction permit was filed with the FCC and late last summer (1949) permission was granted to go ahead with the new setup. Work was started on the new plant in September 1949, at which time two towers were erected, and the concrete footings for the building were poured. All work stopped in November due to winter weather preventing further pouring of concrete.

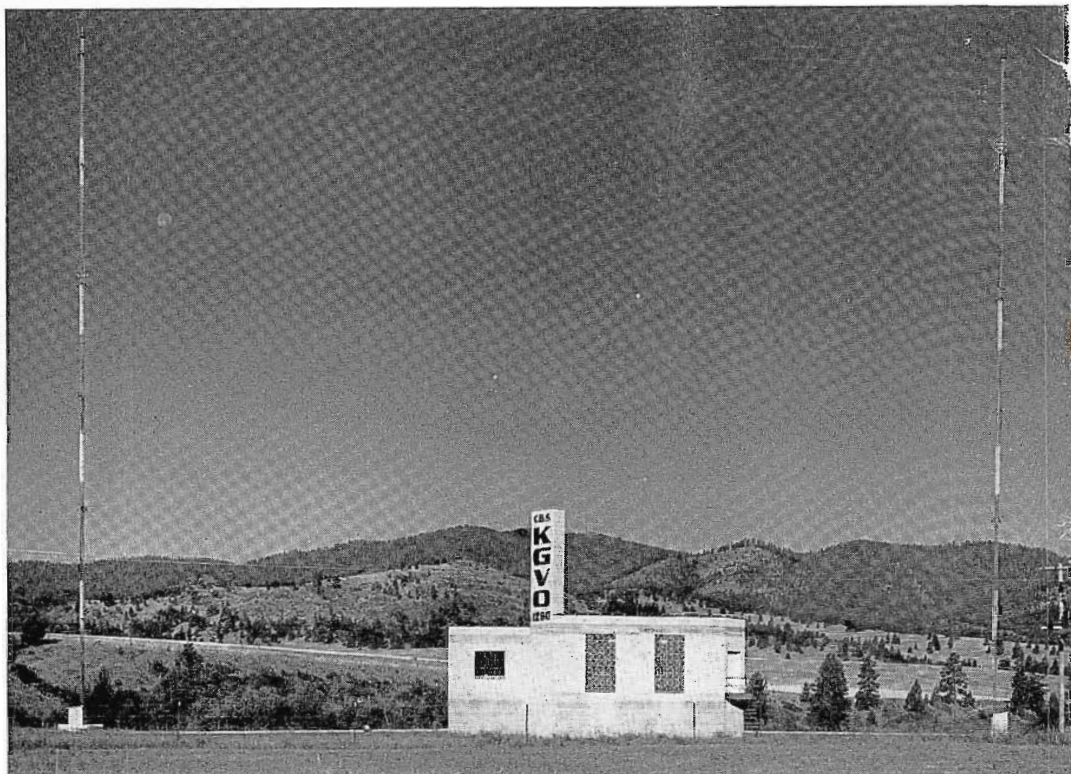
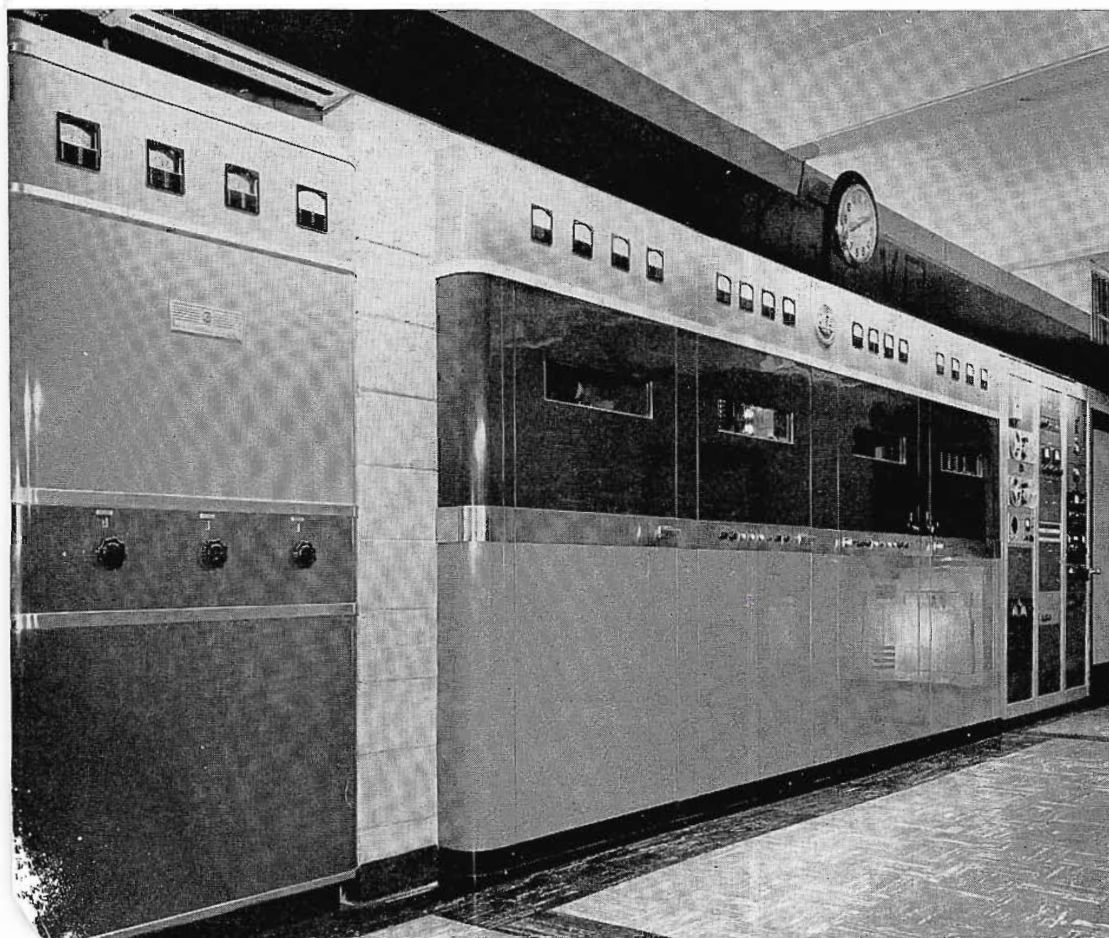

FIG. 1 (above). Exterior view of the KGVO transmitter building with the two-tower antenna array visible in the background.

FIG. 2 (below). In this view are shown the complete transmitting equipments; from left, the RCA custom phasing cabinet, the BTA-5F transmitter, and the audio and monitoring racks.



On an early morning in February 1950 the downtown studios of KGVO were completely destroyed by fire. Due to this fire, plans for the new transmitter building were reviewed and changes made to make the building as fire proof as possible. The original plans called for some of the inside walls to be constructed of wood and plaster but these were changed to concrete block and as a result the only wood in the building is that found on the doors and door frames. All floors, walls and ceilings are of concrete block or poured concrete. All reinforcing steel in the building is welded together and grounded to the antenna ground system to prevent current loops.

As mentioned before, the new KGVO transmitting plant is located five miles south of the city of Missoula in a very picturesque setting of rolling foot hills close by and snow capped mountains in the distance. This site was chosen for its good ground condition. Water can be had at any point on the site by digging down between one and two feet, thus making this one of the best ground systems in this area.

The antenna system employs two 210-foot guyed towers, spaced 135 degrees and beams the signal up the rich Bitterroot Valley to the south and the Flathead Lake region to the north. The ground system is composed of 120 radials, 210 feet long, per

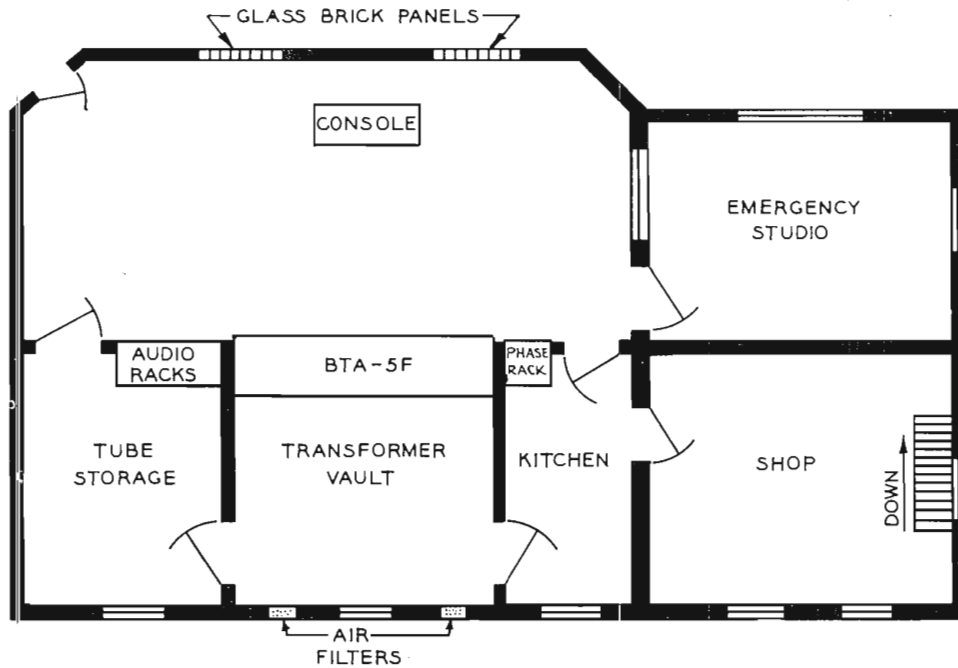

FIG. 3 (above). Floor plan of the KGVO transmitter room which is located on the second floor of the building. First floor is devoted to garage, heating facilities and storage.

tower with radials continuous between the towers. The tuning houses are built up on four-foot stands and are large enough to house the equipment and also leave room in which to work if the weather is bad and shelter is needed. The base insulators of the towers are five feet above the ground, set on solid concrete blocks. This was done to eliminate any possible difficulties with high water. The antenna tuning equipment is custom built by RCA. A seven-eighths inch coaxial transmission line and a three-eighths inch coaxial phasing monitor line run to each tower through a wooden trough built about four feet above the ground. Also contained in the troughs are the power lines for the lights, talking lines for the sound power phones for communication between the towers and the transmitter room, and lines for the remote antenna current meters. The coaxial lines are kept under pressure of dry air by means of an automatic system.

The new transmitter building is a two story structure with the ground floor containing a double garage, furnace room and adequate space for storage. The second floor contains the main transmitter room, emergency studio, transformer vault, combination kitchen and bath, work shop and tube storage room.

The transmitter room contains the RCA BTA-5F transmitter with the supervisory

console and the phasing unit, a recording console and all the necessary speech and monitoring equipment along with tape recorders.

The power and modulation transformers are located directly behind the transmitter in the transformer vault. This space is large enough to permit storage of large tube crates, etc., and is accessible through interlocked doors at either side. All heated air from the transmitter is blown into this space and is drawn either to the outside through a vent on the roof or blown through the building to aid in heating during the winter by a large fan. Fresh cool air is drawn into the transformer vault through two air filters built into the outside wall. These can be closed off if the weather becomes too cold.

From the emergency studio, acting also as office, full control of programming is possible. It contains a studio console and two RCA turntables and an adequate record and transcription library.

The workshop contains a complete set of tools and necessary testing equipment and is modern in every respect.

Since KGVO began operating in 1931, it has always held to its promise to give the listeners and advertisers the best in radio and in keeping with this policy, purchased the RCA BTA-5F transmitting equipment.

FIG. 4 (below). Mr. A. D. Dahl, Chief Engineer of KGVO, is shown seated at the control console of the new RCA BTA-5F transmitter. In the background the emergency studio is visible.

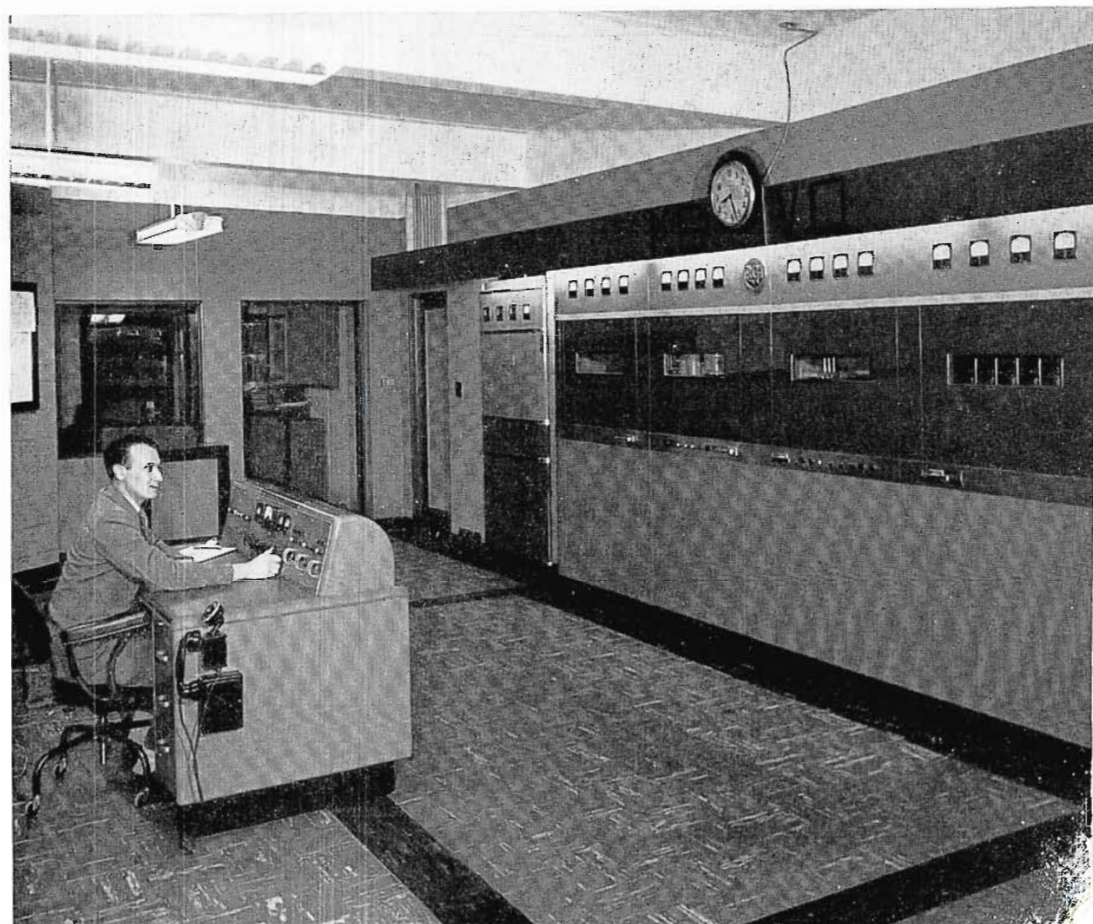

FIG. 1 (at right). The new Lightweight Pickup and Tone Arm combination plays at all speeds and may be applied to existing Broadcast turntables.



NEW LIGHTWEIGHT PICKUP AND TONE ARM

Introduction

The new lightweight pickup and tone arm (MI-11874 and 11885 respectively) have been designed to fulfill the need for a high-quality broadcast pickup combination for playing fine groove records both $33\frac{1}{3}$ and 45 rpm. It appears that the most popular application of this new design will be in combination with the present Universal Pickups for broadcast station installations with RCA 70-D Transcription Turntables.

By

**L. J. ANDERSON
& C. R. JOHNSON**
Audio Engineering Section

In such installations, the new unit will provide the broadcasters with transcription pickup facilities for handling all three speeds, $33\frac{1}{3}$, 78 rpm, and $33\frac{1}{3}$ and 45 rpm fine groove. Existing turntables are easily adapted and present filters in these turn-

tables may be utilized by a simple addition of two or three small components such as resistors and capacitors (see BROADCAST NEWS, No. 58, "How To Use Standard Filters With New Flat Magnetic Pickup").

The new pickups and tone arms are designed to function as a unit and as such offer many outstanding features and advantages over previous units. The basic pickup design is available in two stylus diameters (1 mil stylus for fine groove and

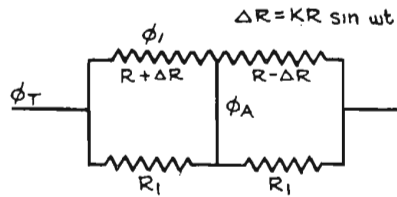
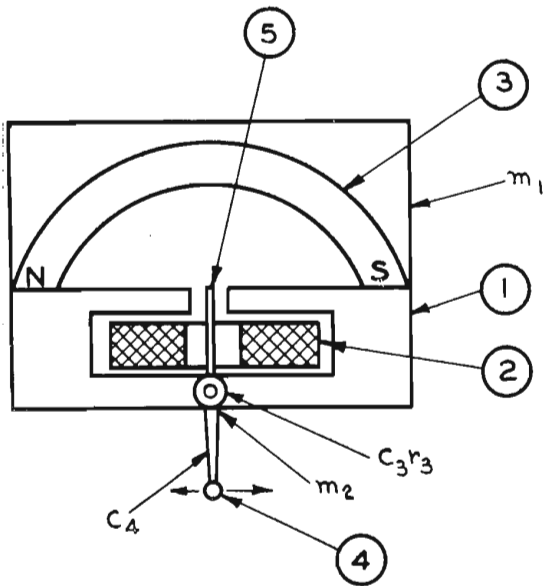

FIG. 2 (at left). Cross-section sketch showing the mechanical circuit of the Lightweight Pickup. (1) Pole Piece, (2) Coil, (3) Magnet, (4) Stylus, (5) Armature.

FIG. 3 (above). Equivalent electrical circuit of the Lightweight Pickup.

2½ mil stylus for standard transcription and 78 rpm records). These are readily interchangeable as units in order to assure optimum results with the present variety of records.

Resonance points have been carefully placed so that they are outside of the operating frequency range of the systems, thus assuring smooth response characteristics. Distortion due to tracking error in the arm and pickup have been reduced to a minimum by careful design. The anti-friction vertical and lateral pivots and low mass allows the tone arm to track warped and eccentric records.

The required stylus forces are only a fraction of what was formerly considered necessary thus assuring longer life for both the stylus and the record. The stylus is readily visible from the top providing simple means for accurately spotting the pickup on the records.

Design Considerations

The introduction of fine groove records (33½ and 45 rpm) of relatively soft materials coupled with a desire on the part of the user for extended frequency range and lower distortion has emphasized many of the problems inherent in the design of pickups and tone arms. Stylus pressures must be reduced compared to past practice in order to assure both long record and

stylus life; and since the fine groove stylus diameter is about 1/3 that used for the 78 rpm home records, the total force which may be safely applied to the stylus will be still further reduced. The fact that the stylus pressure must be low also makes it necessary that the mechanical impedance of the moving system of the pickup be low as viewed from the stylus tip. If this is not so, the pickup will not track well and will cause records to wear rapidly. On the other hand the force must not be too low or the pickup will skip grooves when the turntable is subjected to mechanical excitation

FIG. 4 (below). Size: approximately ¾" x ⅜" x ¼". Weight: approximately ½ ounce.

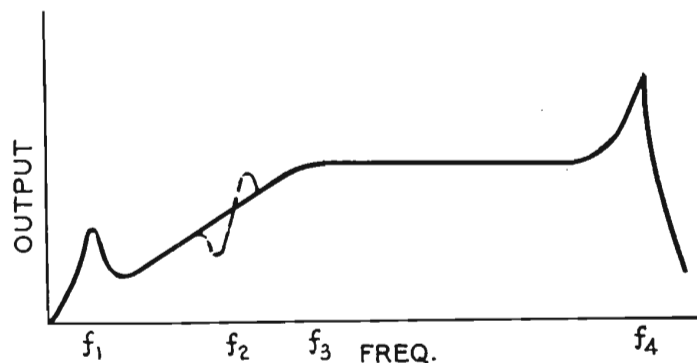
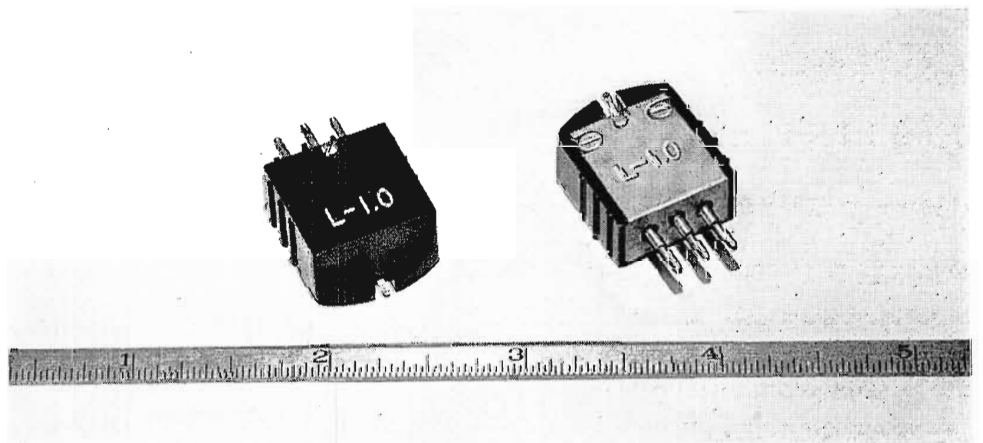

TYPICAL RESPONSE (a)

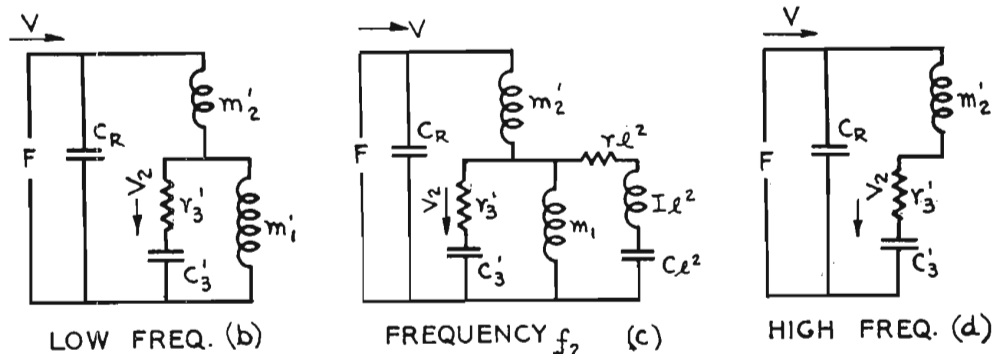

FIG. 5 (at right). Typical Response Curve of the combination and equivalent low-, medium- and high-frequency circuits of Pickup and Tone Arm.

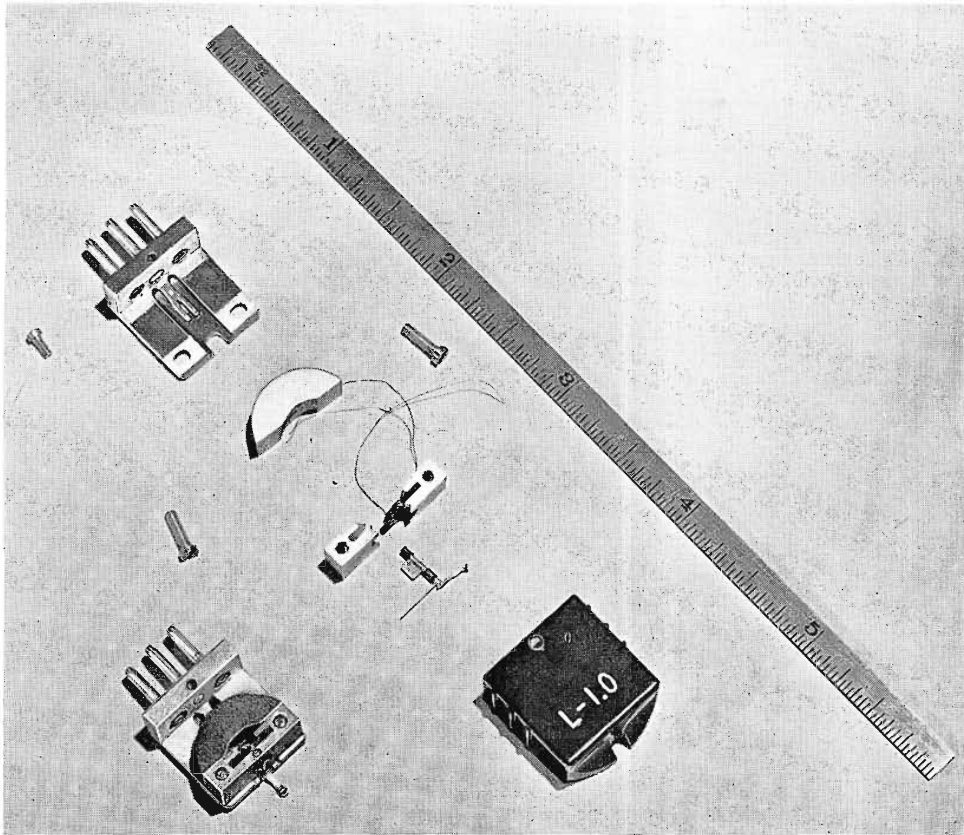

FIG. 6 (above). Exploded view of the Lightweight Pickup showing the small-size and construction of the individual components.

such as might be experienced due to building vibration. The proper choice of mechanical constants and materials for the pickup parts are a "must" in order to assure low distortion, adequate sensitivity, low acoustic noise, long life, and smooth response-frequency characteristics.

A truly universal pickup is no longer possible without considerable compromise because of the fact that the difference in groove dimensions between 78 rpm home records and fine groove records is so great. A stylus which will satisfactorily play 78 rpm home records will ride the top edges of the cut on fine groove records, and a pickup stylus specifically designed for fine groove records will ride the bottom of the groove in 78 rpm home records. Both conditions will result in noisy reproduction and possibly poor tracking. It is, therefore, desirable that the pickup and arm though designed to operate as a unit, be separable to the extent that for each type of record a pickup having the optimum size stylus be available.

The tone arm should have bearings with low coefficients of friction and the inertia

about both the horizontal and vertical pivots should be low so that excessively large forces will not be applied to the stylus when wavy records, or records with eccentric grooves, are played. Care must also be taken to place tone arm resonances below the audio range, but not in the range where the system may be excited by the wavy starting grooves which are present in some 78 rpm home records.

The Lightweight Pickup

Though the performance of the pickup as a transducer is dependent upon the tone arm with which it is to be used, it appears to be most convenient to first consider the pickup by itself and follow with the design of a suitable tone arm.

Fig. 3(a) shows the essential parts of the pickup in schematic fashion. In general it follows the conventional arrangement of magnetic pickups excepting that the parts have been scaled down in size, for reasons which will later become obvious. Fig. 3(b) shows a schematic of the magnetic circuit.

ϕ_T = Total flux supplied by the magnets to the pole structure.

ϕ_A = The flux which flows through the armature.

R_1 = The reluctance of the gaps at the bearing point.

R = The reluctance of the airgaps on each side of the centered armature.

K = Constant whose value depends on the amplitude of motion imparted to the armature.

The total flux ϕ_T supplied by the magnets remains essentially constant and the position of the armature in the gap is represented by the slider moving along the upper reluctance. ϕ_A is the flux through the armature, whose reluctance is assumed to be negligible compared to the gap reluctances.

An analysis of this circuit shows that:

$$(1) \quad \phi_A = \frac{2\phi_T R_1 K R \sin \omega t}{(R_1 + R)^2 - K^2 R^2 \sin^2 \omega t}$$

In order to avoid distortion in the system $K^2 R^2$ must be kept small compared to $(R_1 + R)^2$. If this is done, equation (1) becomes

$$(2) \quad \phi_A = \frac{2\phi_T R_1 K R \sin \omega t}{(R_1 + R)^2}$$

$$(3) \quad \frac{d\phi_A}{dt} = \frac{2\phi_T R_1 K R \omega \cos \omega t}{(R_1 + R)^2}$$

$$(4) \quad e = N \frac{d\phi_A}{dt} = \frac{2N \phi_T R_1 K R \omega}{(R_1 + R)^2}$$

Where N = Number of turns on the pickup coil.

As long as the amplitude constant K is in proportion to $\frac{1}{\omega}$ the output voltage

will remain constant. In other words when the armature is driven at a constant velocity, relative to the pole pieces, the output voltage will remain constant. This velocity is a function of the cut on the record and the mechanical constants of the pickup.

Fig. 3(a) shows the essential elements of the mechanical system.

m_1 = the total mass associated with the pickup body.

m_2 = the mass of the armature.

c_3 = the combined compliance of the centering spring and the rubber bearings.

r_3 = the resistance of the rubber bearings.

The value of c_3 may be as much as twice as that which the mechanical constants would indicate because of the reduction in stiffness produced by the magnetic field. ¹The equivalent circuit for the pickup and record is shown in Fig. 5(b) where C_R = the mechanical compliance of the record material. m_2' , m_3' , r_3' and c_3' are identical with the elements in 3(a) except that they are now referred to the stylus tip. Since the output of the pickup will be proportional to the difference between the velocity of the armature and the pole pieces, V_2 will be a measure of the output voltage.

There are two conditions which will make V_2 a maximum even though the velocity V remains constant. At some frequency f_1 , m_1' and c_3' will form a resonant circuit. Values of m_1 and c_3' must therefore be chosen so that f_1 lies below the operating range of the system. A frequency somewhere in the range from 15-25 cycles is satisfactory. Since m_1' is small c_3' will be large and the pickup will not be stiff when viewed from the stylus tip. At a higher frequency f_4 a resonance will occur between C_R , the compliance of the record material, and m_2' the mass of the moving system. At this frequency m_1' the mass of the pickup may be neglected. Fig. 5(a) shows this peak at f_4 . Since the value of C_R is fixed by the record material and the dimensions of the stylus, the mass of the moving system must be made sufficiently small so that this resonance occurs beyond the working range of the pickup. In practice the frequency is of the order of 15 kc and the associated filter is designed to cut off the peak.

¹"Electromechanical and Electroacoustical Analogies." Akademiet for de tekniske videnskaber og dansk ingenirforening. 1947, No. 1, Pages 40-45.

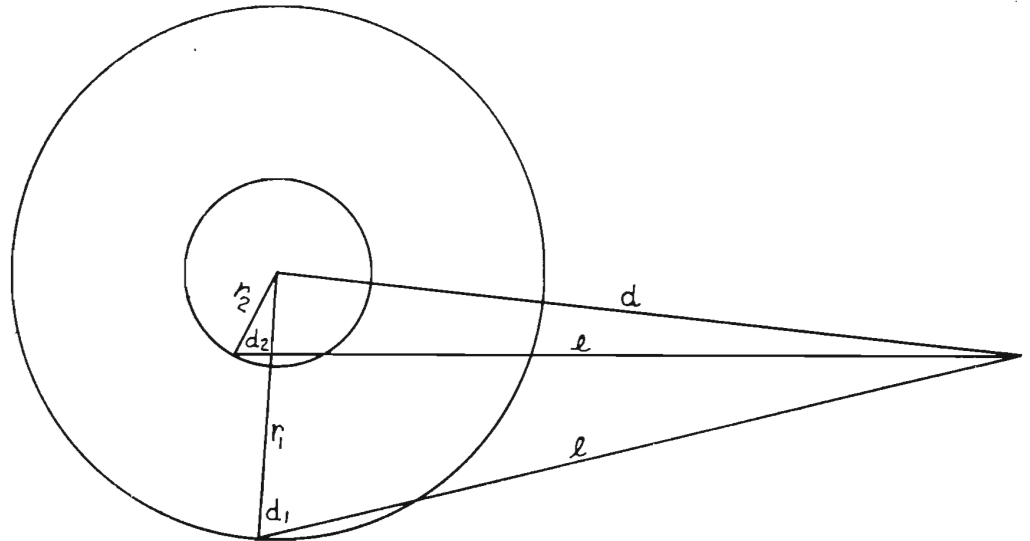

FIG. 7 (above). Sketch showing the essential Tone Arm and Disc dimensions.

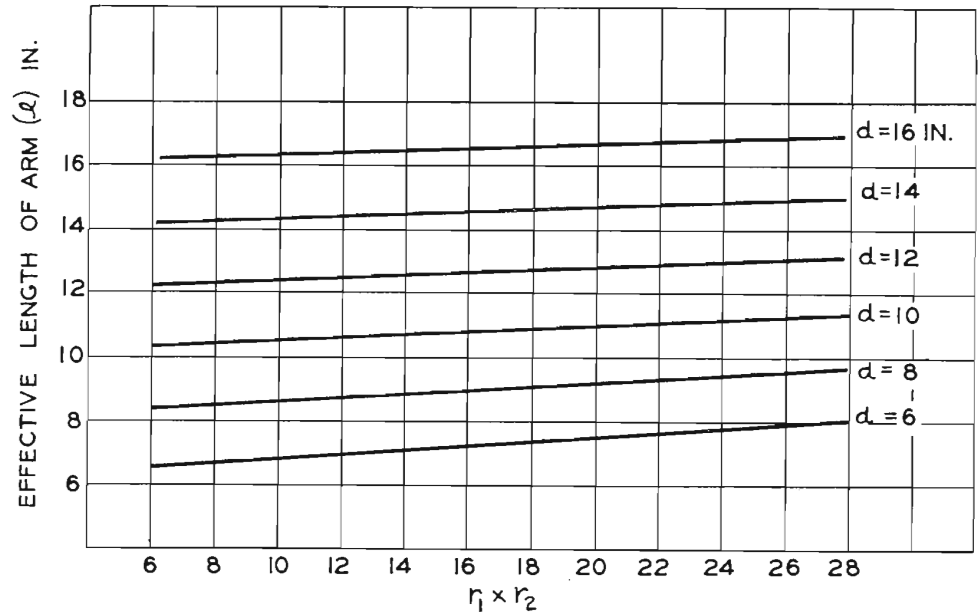

FIG. 8 (above). Curves showing the correct length of arm as a function of center distance and radii of records.

Fig. 4 shows the appearance and size of a commercial pickup designed along these lines. Two stylus sizes are currently being made, (1.0 mil and 2.5 mil), both diamond tips to assure long life. A total force of 8 grams is required for the 1.0 mil stylus and 12 grams for the 2.5 mil stylus. The pickups may be readily interchanged and the difference in the required stylus force is obtained by internally weighting the pickup having the 2.5 mil stylus. No change in tone arm balance is therefore required when pickups are interchanged. The covers are colored to permit

easy identification, red for the 1.0 mil stylus and green for the 2.5 mil stylus. Fig. 6 shows the internal parts along with a scale so that their size may be judged.

The Tone Arm

With the pickup completed, the problem of designing a satisfactory tone arm remained. The tone arm described in the following is the result of a long series of experiments with arms of different types; arms which were spring balanced instead of counter weighted, arms in which the arm section was rigid and the pickup head

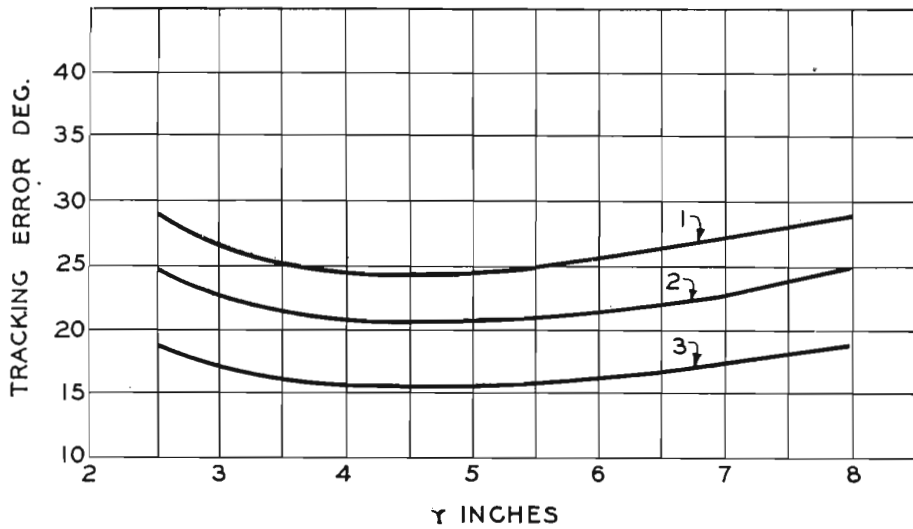

FIG. 9 (above). Curves showing tracking error for a straight arm: (1) $d = 10$ in., (2) $d = 12$ in., (3) $d = 16$ in.: $l = 11.0$ in., $l = 12.8$ in., $l = 16.7$ in. respectively: $r = 8$ in. and $r_2 = 2.5$ in.

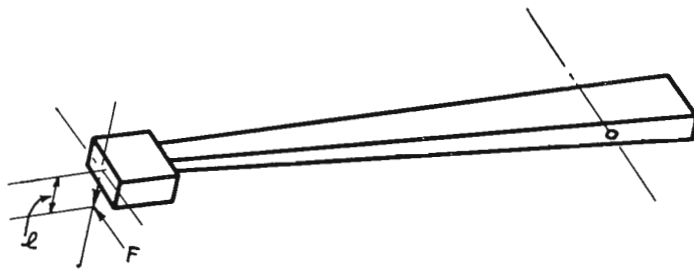

FIG. 10 (at left). Mechanical sketch showing the Pickup and Tone Arm combination.

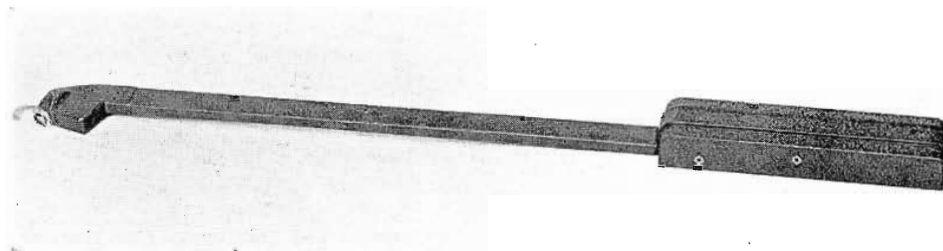

FIG. 11 (above). Photo of an early experimental Lightweight Tone Arm.

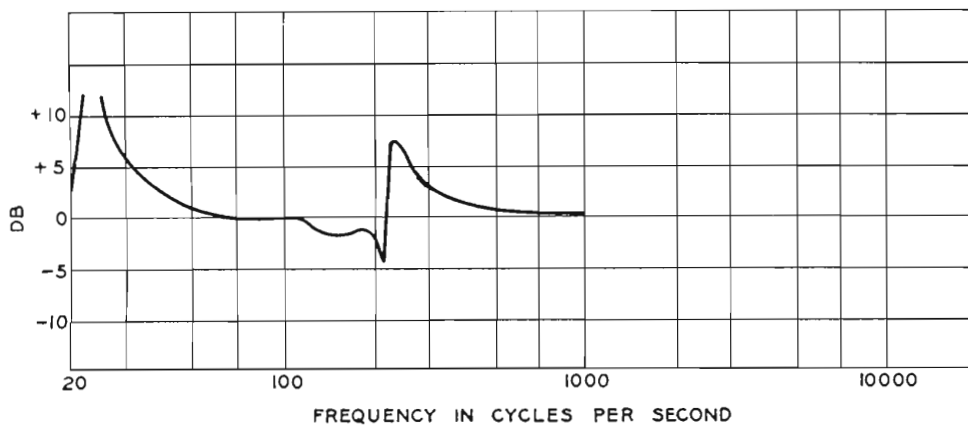

FIG. 12 (above). Curve showing the Torsional Resonance in Tone Arm of Fig. 11.

pivoted, arms in which ball bearings were extensively used, all were discarded for one reason or another and the problem resolved itself into refining the design of the more or less conventional tone arm.

Tracking Error

Error in tracking occurs whenever the record radius through the stylus point does not coincide with the path along which the stylus is driven by the record modulation. The distortion introduced is a function of the wavelength of the recorded signal and becomes increasingly serious for high frequencies and the inner record grooves. The tracking error is a function of the effective tone arm length, the distance from the center of the turntable to the vertical axis of rotation of the arm, and the position of the pickup on the record. The effective length of the arm is the distance from the stylus tip to the vertical axis of rotation for the arm.

Increasing the length of the arm will make decreasing values of tracking error possible. Since there are obviously physical limitations to the arm length, the expedient of turning the pickup head at an angle to the arm is an excellent means of reducing the tracking error. The scheme is to so select the effective arm length and pivot position that the angle of error at the outside of the largest, and the inside of the smallest records to be played will be equal. The head is then offset by this angle and as a result the tracking error at the extremes will be zero and, as will be shown, the error at intermediate points is also small. Fig. 7 shows the essential tone arm and disc dimensions.

l = the distance from the stylus to the vertical axis of rotation for the arm.

d = the distance from the center to the turntable to the vertical axis of rotation for the arm.

r_1 & r_2 = the radii at which the tracking error is to be made equal for a straight arm.

B = tracking error ($90^\circ - \alpha$).

From the cosine law for a triangle

$$(5) \quad \cos \alpha_1 = \frac{r_1^2 + l^2 - d^2}{2r_1l}$$

$$(6) \quad \cos \alpha_2 = \frac{r_2^2 + l^2 - d^2}{2r_2l}$$

If α_1 is then assumed to be equal to α_2 the two above equations may be solved for l

$$(7) \quad l = \sqrt{d^2 + r_2 r_1}$$

The above function is plotted in Fig. 8 and the only restriction, for practical purposes, in the selection of d and l is that d should be larger than r_1 .

When the proper arm length has been calculated or selected from the above, the offset angle B to make the tracking error zero at both the inside and the outside of the record may be calculated from

$$(8) \quad B = (90^\circ - \alpha_1)$$

$$(9) \quad B = 90^\circ - \cos^{-1} \left[\frac{r_1^2 + l^2 - d^2}{2r_1 l} \right]$$

Fig 9 shows a plot of the above for several conditions. If the head is offset by the angle shown for the end points of the curves, the maximum tracking error will be the difference between highest and lowest points. For the worst condition shown this is less than 5° .

The radius at which the deviation will be a maximum may be determined by:

$$(10) \quad \frac{d \cos \alpha_1}{dr} = \frac{r^2 - l^2 + d^2}{2r^2 l}$$

$$(11) \quad r = \sqrt{l^2 - d^2}$$

The value α_3 at this value of r will be:

$$(12) \quad \alpha_3 = \cos^{-1} \left[\frac{\sqrt{l^2 - d^2}}{l} \right]$$

The maximum tracking error which will result when the head is offset an angle B will be $(\alpha_1 - \alpha_3)$.

The effective length chosen for the first experimental arms was 16.7 inches resulting in a maximum tracking error of $3^\circ 40'$.

Tone Arm Resonances

At this point a word regarding the method of measuring the tone arm performance is in order. Test records having discreet frequency bands resulting in point-by-point data are generally not suitable for exploring tone arm performance because of the sharpness of the arm resonances encountered. Therefore, continuous curves

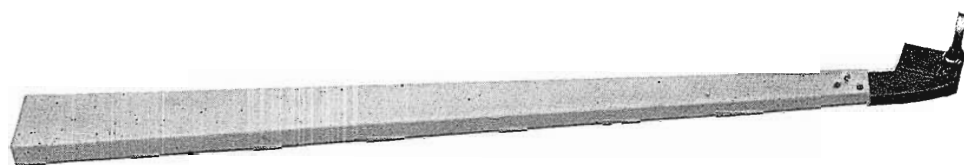

FIG. 13 (above). Photo of an experimental arm of Box Section type.



FIG. 14 (above). Underside view of the "Box-Section" tone arm also shown in Fig. 13.

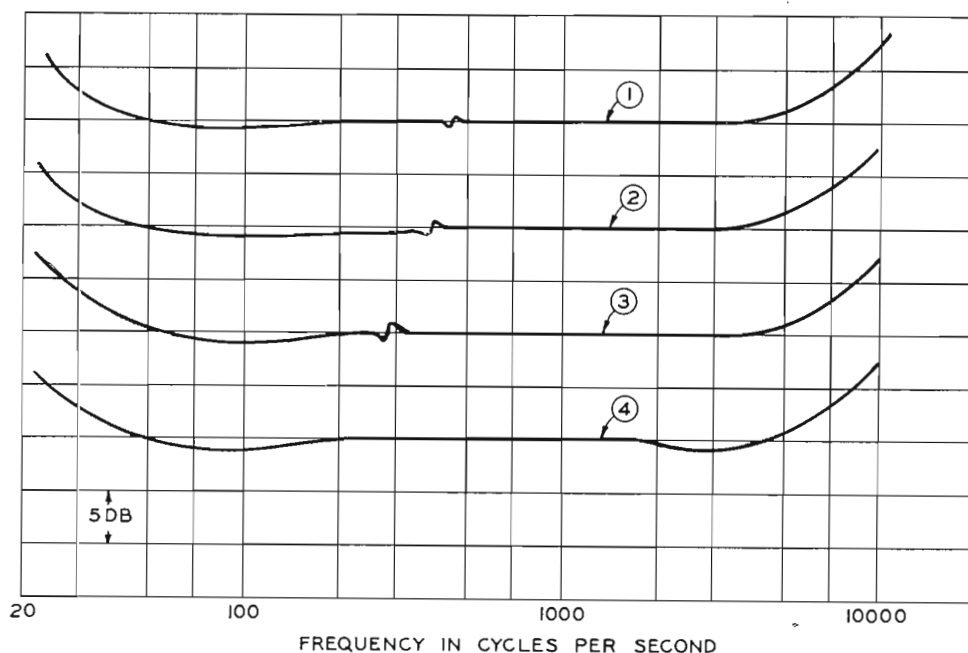

FIG. 15 (above). Family of curves showing the Torsional Resonance in the experimental tone arm of Fig. 14. (1) Tone Arm with plate welded to bottom, (2) Tone Arm with $\frac{1}{8}$ " wall, (3) Tone Arm with $\frac{3}{32}$ " wall, (4) Final Design.

were taken on all tone arms by the following method. A disc record was cut from the output of a beat frequency oscillator when the oscillator was driven through the frequency range by mechanical linkage to a continuous curve recorder. The testing then simply consisted of playing back the disc using the arm and pickup under test and recording the output on the curve recorder which was used to drive the oscillator when the disc was cut. The result is a continuous record of the output vs. frequency. Final data was taken by the Variable Speed Turntable method for greater accuracy.¹

Fig. 11 is a photograph of the first attempt at a lightweight tone arm and the

response-frequency characteristic of this arm is shown in Fig. 12. This tone arm was made with the arm portion, a box section of very thin aluminum alloy in order to keep the moment of inertia about the vertical and horizontal pivots a minimum. In addition to the usual resonance at about 25 cycles another disturbance takes place around 160 cycles. This is due to a torsional resonance in the arm. The equivalent circuit and the responsible elements are shown in Fig. 5(c); rI^2 , II^2 and CI^2 are respectively the torsional resistance, inertia and compliance of the arm referred to the stylus tip.

Stiffening the arm without appreciably increasing the mass will raise the frequency

and reduce the amplitude quite rapidly without impairing the tracking properties. This was accomplished in the second model shown in Fig. 13 and Fig. 14. The arm is a tapered rectangular box section of 0.062 inch thick aluminum alloy. The response frequency characteristic of this arm is shown in Fig. 15.¹ Box sections were used for the original experimental arms because of the relatively high stiffness to mass ratios which can be obtained. Box sections do not, however, lend themselves readily to easy manufacture and to shapes of pleasing appearance, and for these reasons experiments were continued with a channel structure of fairly large section. The general shape of the arm was the same as that shown in Fig. 11 and the wall thicknesses tried were 1/8 and 3/32 inches. The results are shown in Fig. 15 curves 2 and 3 and it will be noted that even with

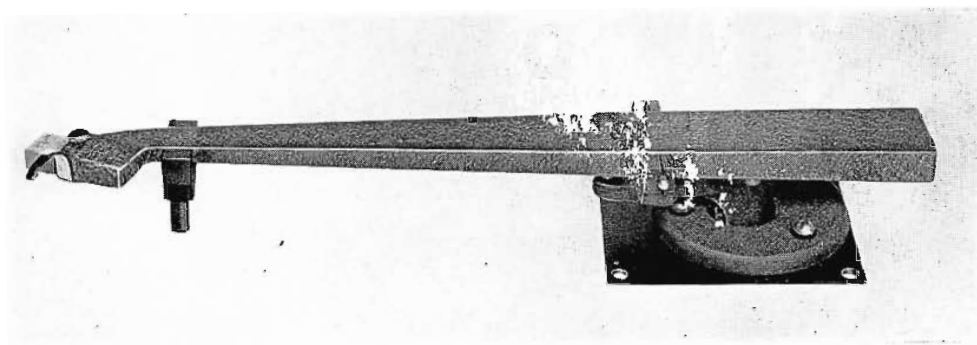

FIG. 16 (above. View of the final design of the Lightweight Tone Arm complete with Pickup, mounting plate and arm rest.

the heaviest wall the results are not quite as good as those obtained with the box section 15.

The final design was obtained by shortening the original arm length of (16.7)

¹ "A Variable Speed Turntable and Its Use in the Calibration of Disk Reproducing Pickups." H. E. Haynes, H. E. Roys. Proc. IRE, Vol. 38, No. 3, March 1950.

inches to an effective length of 12 inches. The maximum tracking error increased to about 4°, not enough to be serious, and at the same time the arm length became such as to greatly facilitate its use with existing turntables.

Final Design

The final design of the arm and mounting is shown in Fig. 16 and mounted on a turntable in Fig. 18. Overall playing performance with standard test records and the recommended filters is shown in Fig. 17.

Playing tests have shown that this pickup and arm will track wavy records, records with wavy start grooves and eccentric records with stylus forces of 12 grams for the 2.5 mil stylus and 8 grams for the 1 mil stylus.

Intermodulation tests yield results which are low to the point where it is not possible to accurately determine whether the distortion is in the record or the pickup.

In conclusion the authors wish to acknowledge the extensive contributions of Messers. H. E. Roys, E. Masterson and L. W. Ferber of the Engineering Department, RCA Victor Division.

"Tracking Angle in Phonograph Pickups," B. B. Bauer. Electronics 18:110-15, March 1945.

"Intermodulation Distortion Analysis as Applied to Disk Recording and Reproducing Equipment," H. E. Roys. IRE Proc. 35: 1149-52, October 1947.

"Determining the Tracking Capabilities of a Pickup," H. E. Roys. Audio Eng., May 1950.

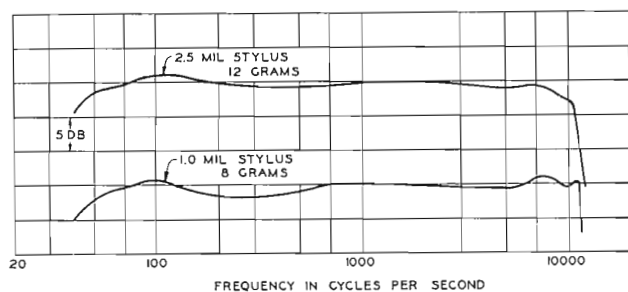

FIG. 17 (at left). Typical Response curves of the Lightweight Pickup, Tone Arm and filter.

FIG. 18 (below). View of famous RCA 70-D Broadcast Turntable with Lightweight Pickup and Tone Arm at rear. At right is existing arm which may also be used at 33 1/3 and 78, when desired.



A METHOD OF DETERMINING THE TRACKING CAPABILITIES OF A PICKUP

by

H. E. ROYS

Engineering Products Department
RCA Victor Division, Camden, N. J.

Introduction

A pickup that is used for the purpose of reproducing disk records relies upon the mechanical contact between groove and stylus tip for actuation of the stylus. For, in order to obtain faithful reproduction, it is necessary that the stylus "track" or maintain good mechanical contact with, and exactly follow the undulations of the recorded groove. Where we are dealing with lateral recordings, and these form the bulk of the records in use today, we are primarily concerned with the contact between stylus and groove side walls as illustrated by Fig. 1-A. When the groove changes laterally from a mean position, due to the modulation, it is the side walls of the groove that exert a side thrust upon the stylus to make it follow. If the vertical force is low, the stylus will climb the side wall as illustrated in Fig. 1-B, and then the effectiveness of the pinch of the "V" shaped record groove is lost and poor tracking and distortion results.

Tracking has been a problem even from the beginning of disk recording, when the usual vertical force was one half a pound instead of one half an ounce. For it is only by using adequate vertical force that the stylus can be held in the groove and maintain good mechanical contact with the side walls. The tracking problem still exists today even though vast strides have been made in the reduction of pickup mechanical impedance with a resulting improvement in tracking. Fine groove reproduction with a small stylus tip requires low vertical force if a minimum of record and stylus wear is wanted.

Method of Measurement

Since the tracking capabilities of a pickup depend upon its mechanical impedance, a measure of the mechanical impedance is also an evaluation of its ability to faithfully follow the recorded groove.

Determining the mechanical impedance is not a simple measurement nor is it completely adequate. For example, practically all of the pickup and tone arm combinations tend to climb the groove side walls, rattle and even skip out of the groove at

FIG. 1a. This shows an ideal "fit" between stylus and groove side walls.

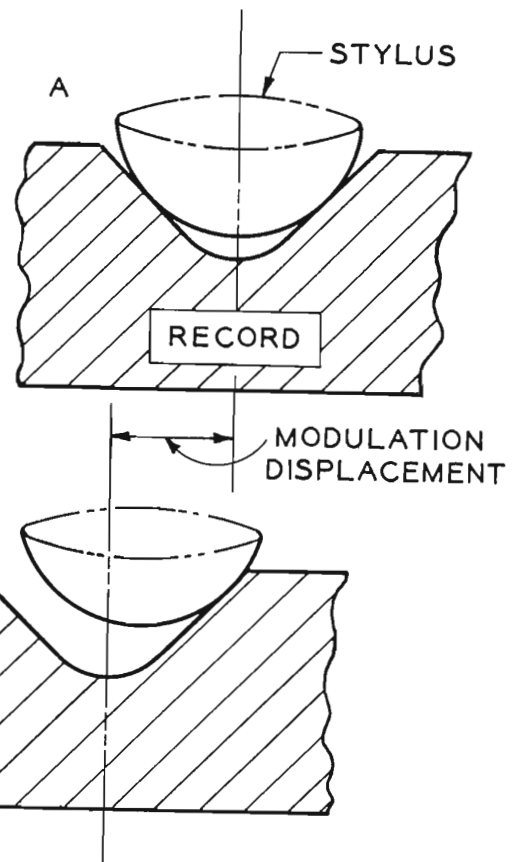

FIG. 1b. When the groove is displaced laterally from the mean position due to modulation, the tip, if the mechanical impedance of the pickup is high, will climb the side wall of the groove and an increased vertical force is needed to hold it in the groove.

tone arm resonance, and although skipping is not common at the high frequency resonance, changes in response at resonance can be noted unless sufficient vertical force is used, see Fig. 2. The mechanical impedance is high at the two resonant points and usually the vertical force has to be increased several times over its normal value in order to keep the pickup stylus firmly in the groove. Yet listening tests indicate that the quality of reproduction is acceptable with the lighter force. This may be so due to the fact that the mechanical impedance between the resonance frequencies is low, and it is throughout this region that the peak energies of speech and music are encountered, so that although the tracking requirements may be severe, the vertical force requirement is not great.

The intermodulation method of distortion analysis appears to be a good method of studying the tracking capabilities of a pickup, especially when using frequencies of 400 and 4000 cycles. For these frequencies lie between the two resonant frequencies of the pickup system and are located in the region where high peak energies of speech and music are normally

encountered. The method is sensitive, and yet the measurements are simple and easy to make. In addition, measurement equipment is not absolutely necessary, as a great deal of useful information can be obtained by simply listening to the reproduction of the test record. In fact, the test record is probably the most valuable item of the test.

The Test Records

For tracking studies, 78 and 45 RPM records cut by Mr. R. C. Moyer of our Indianapolis Plant are used. These were cut at different levels up to 10 db above an assumed normal recording value. Levels as low as minus 6 db were also included so that an overall range in 2 db steps, from -6 to +10 db is available when using the 78 RPM record and from -4 to +10 db with the 45 RPM record.

The two frequencies were combined in the normal manner for the intermodulation signal, 400 cycles for the low frequency and 4000 cycles for the high with the 4000 cycle tone 12 db below the 400 cycle signal in level. The 0 db or normal level for the 45 RPM record was made approximately 3 db lower than the 78 RPM

value in accordance with the general practice of cutting fine groove records at a reduced level in order to avoid cutting into adjacent grooves, and also to minimize tracing distortion. The peak value of the 0 db or normal levels as measured by the optical pattern method, while the pressings were being rotated (a necessity where two frequencies are combined in order to obtain an accurate evaluation of the pattern width) was measured to be 6 centimeters a second for the 45 RPM record and 8.7 centimeters a second for the 78 RPM record. The maximum peak recorded levels attained is about 27 and 18 centimeters a second for the 78 and 45 RPM records respectively. It is difficult to determine just what peak levels are encoun-

tered in phonograph records, but it is believed that the levels on the test records are adequate for pickup tracking studies. The RCA 45 RPM record system design is based upon a maximum recording level of approximately 14 centimeters a second.

Both records were cut with a stylus having a tip radius of less than 0.0005 inch, so a fine groove pickup having a tip radius of 0.001 inch can be used with either record. The 78 RPM record,* 12-5-39, has a groove wide and deep enough to accommodate pickups that have a tip radius of 0.003 inch such as normally used for 78 RPM reproduction. The 45 RPM record,* 12-5-37, has a narrow groove suitable only for reproduction with a pickup having a 0.001 inch tip radius.

Test Procedure

Intermodulation test frequencies of 400 and 4000 cycles have been found to be particularly useful for studies of distortion in disk recording and reproducing systems. Fig. 3 shows a block diagram of the equipment we have been using and also illustrates what the test signal, a combination of two frequencies, looks like on an oscilloscope and also how the distortion appears as modulation of the 4000 cycle carrier.

In determining the tracking capabilities of a pickup either the 45 or 78 RPM intermodulation record is played while using various vertical forces and the distortion is measured for each different recorded level. The results when plotted give a set of curves such as illustrated in Fig. 4. In general, the distortion is low for the low values of recorded signal, but at some higher level an abrupt change is encountered and the distortion increases rapidly as the recorded level is raised. Increasing the vertical force shifts the breaking point to a higher recorded level and by using sufficient vertical force, good tracking can be obtained at the highest levels available on the record.

Where the distortion appears abruptly and increases so rapidly with recorded level, it appears permissible to define good tracking in terms of vertical force and the recorded level where the break occurs.

Fig. 5, however, gives the results obtained with the 45 RPM record, and shows the breaking point with resulting rise in distortion to be less abrupt than obtained with the 78 RPM record. This makes it difficult to determine good tracking as defined above and it may be necessary to establish some value of intermodulation, such as 10 percent for example, as the limiting value. Then for the pickup illustrated in Fig. 5 with a vertical force of 5 grams, good tracking can be expected for recorded levels up to about 17 centimeters a second.

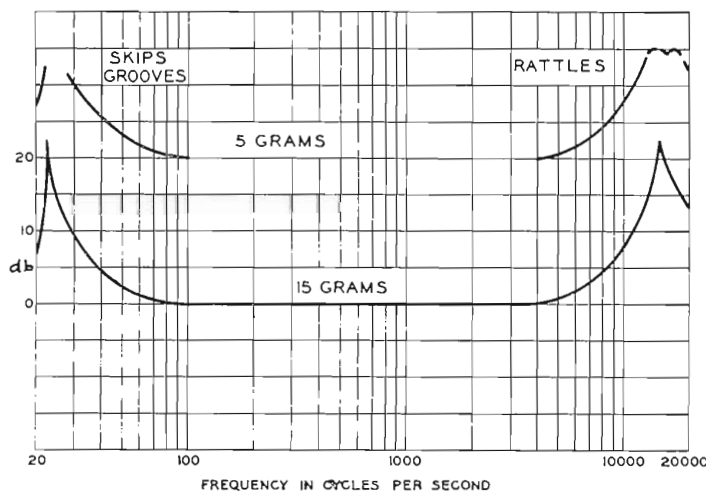

FIG. 2. Frequency response characteristic taken by the variable speed method. The peak at the low frequency end is due to tone arm resonance and the one at the high frequency end, due to pickup resonance. Mechanical impedance characteristic is similar to this in shape.

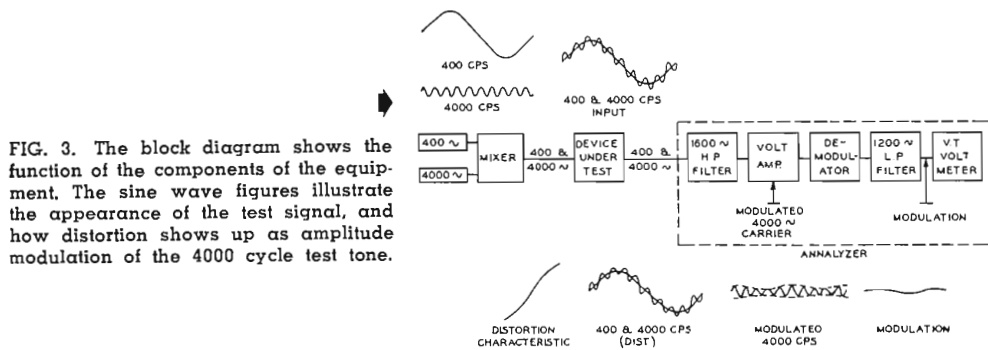

FIG. 3. The block diagram shows the function of the components of the equipment. The sine wave figures illustrate the appearance of the test signal, and how distortion shows up as amplitude modulation of the 4000 cycle test tone.

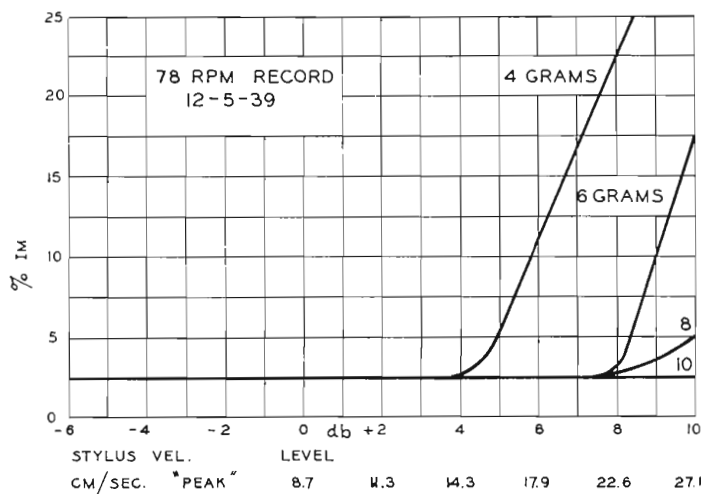

FIG. 4. Distortion curves obtained with the RCA MI-11874 magnetic pickup, illustrating its tracking capabilities and improvement obtained as the vertical force is increased.

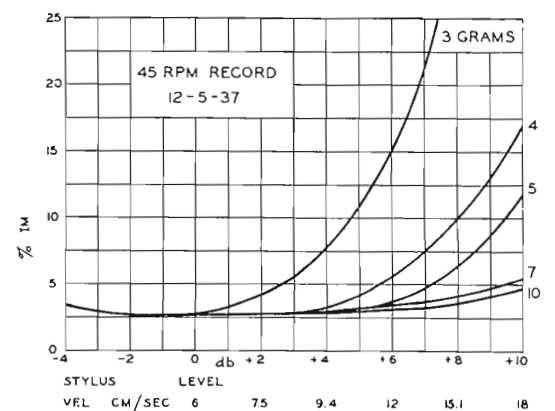

FIG. 5. Characteristics obtained with MI-11874 pickup when using the 45 rpm test record.

Ten percent intermodulation when using test frequencies of 400 and 4000 cycles, is a figure that has been arrived at after many careful listening tests over a wide range system as the value at which tracing distortion becomes perceptible. It is the value that has been used to establish the inner recorded diameter of RCA's 45 RPM records. Good correlation has been obtained between measurements and listening tests, and more recent tests indicate that the intermodulation method is as equally useful in determining the tracking capabilities of pickups.

When making tracking measurements, it is often advisable to listen to the output of the test record in order to detect any irregularities that may occur due to record eccentricity or wobble causing a once-around variation in distortion at turntable speed (due perhaps to excessive friction in the tone arm bearings). Such variation may be so slight that it does not register on the meter, especially if the meter is sluggish in action, and hence, may be overlooked unless listening tests are made.

When making comparison tests with records containing music, the pickup will usually appear to track better than indicated by the intermodulation test records. In such cases it is possible that the peak velocity on the music record is not as high as expected or that its duration is so short that tracking distortion is not readily apparent. If a number of tests are made, especially while using a wide range system so that tracking distortion can be readily detected, it is believed that on the average, the agreement will be found to be good between measurements and listening tests.

Effect of Damping

It is the usual practice in pickup design to incorporate some mechanical resistance to smooth out the resonant peak of the pickup. The effect of the damper is usually judged by frequency response measurements. During tracking studies it was noted

that the damping material can have a detrimental effect upon tracking. A sliver of viscoloid between the stylus and case of the pickup, used for the tracking tests of Fig. 4, gave the results shown in Fig. 6. The sliver was small and had little effect upon the response characteristic, but the effect upon the tracking capabilities was such that the intermodulation increased from about 6 to 16 percent at a recorded level of 27 centimeters per second.

A large stiff block of viscoloid was tried in the same location with another pickup and the results with and without the damper are shown in Fig. 7. In this case the damper block was so stiff that it affected the tracking capabilities even at the lowest recorded levels. This is an unusual example, but it serves to illustrate that the damper block should be added with care, and the effect upon tracking as well as frequency response should be investigated.

Pickups of Different Design

Several pickups of different design were investigated for tracking capabilities. The same vertical force was used and the results are shown in Fig. 8. Two of the pickups were of the same type with minor changes in construction but considerable difference in the amount of damping material that was used. One pickup used no

damping material, and another used a moderate amount. The pickup that used the greatest amount of damping material exhibited the poorest tracking capabilities, confirming the results of our tests as given above.

Conclusions

1. The intermodulation method of distortion analysis appears to be valuable in determining the tracking capabilities of a pickup. By reproducing intermodulation frequencies that have been recorded at different levels, the necessary value of vertical force needed to insure proper tracking can be easily determined.

2. Measurement equipment, although needed for a careful analysis, is not essential, as much useful information can be obtained by listening to the output of the test record.

3. Damping material so commonly used in pickup construction in order to obtain smooth response characteristics may adversely affect the tracking capabilities of the pickup and therefore should be investigated carefully and used judiciously.

References

* These records can be obtained from the Custom Record Sales Section, RCA Victor Division, 120 E. 23rd Street, New York, N. Y.

FIG. 6 (below). A small piece of viscoloid when applied for mechanical damping caused this change in tracking capabilities.

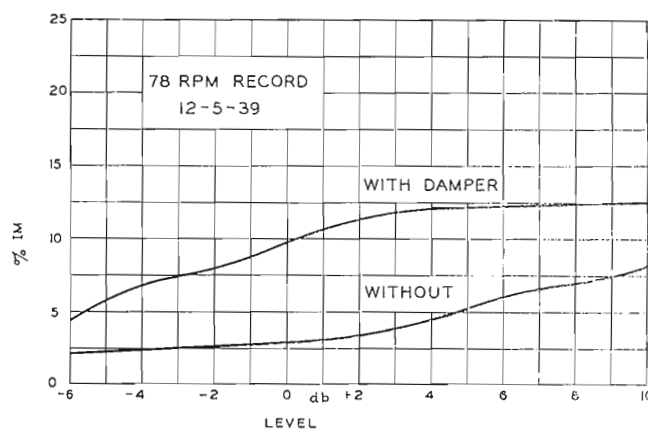

FIG. 7 (at left below). A larger piece of viscoloid had a detrimental effect upon tracking throughout entire recorded range.

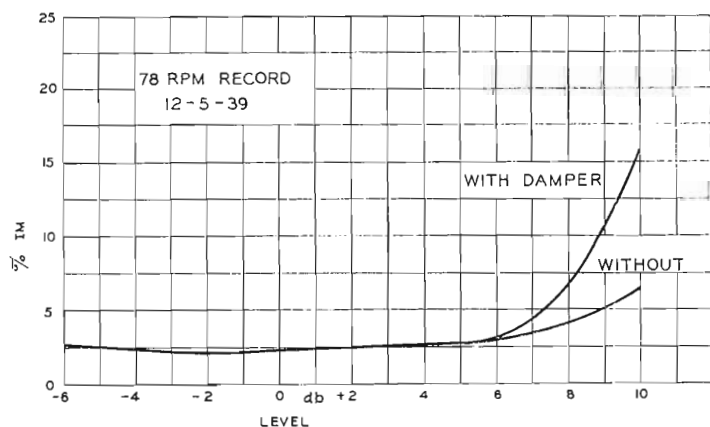
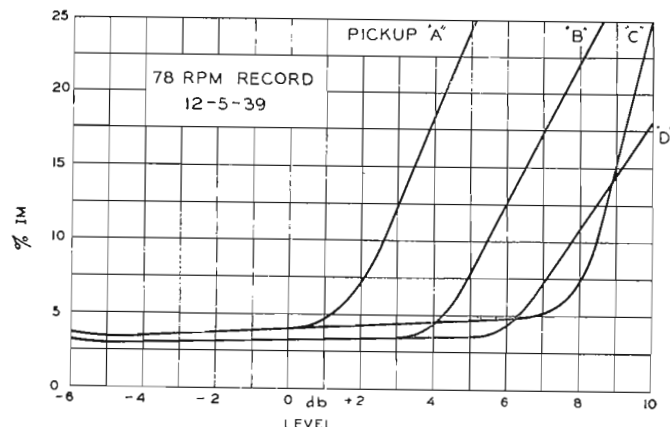
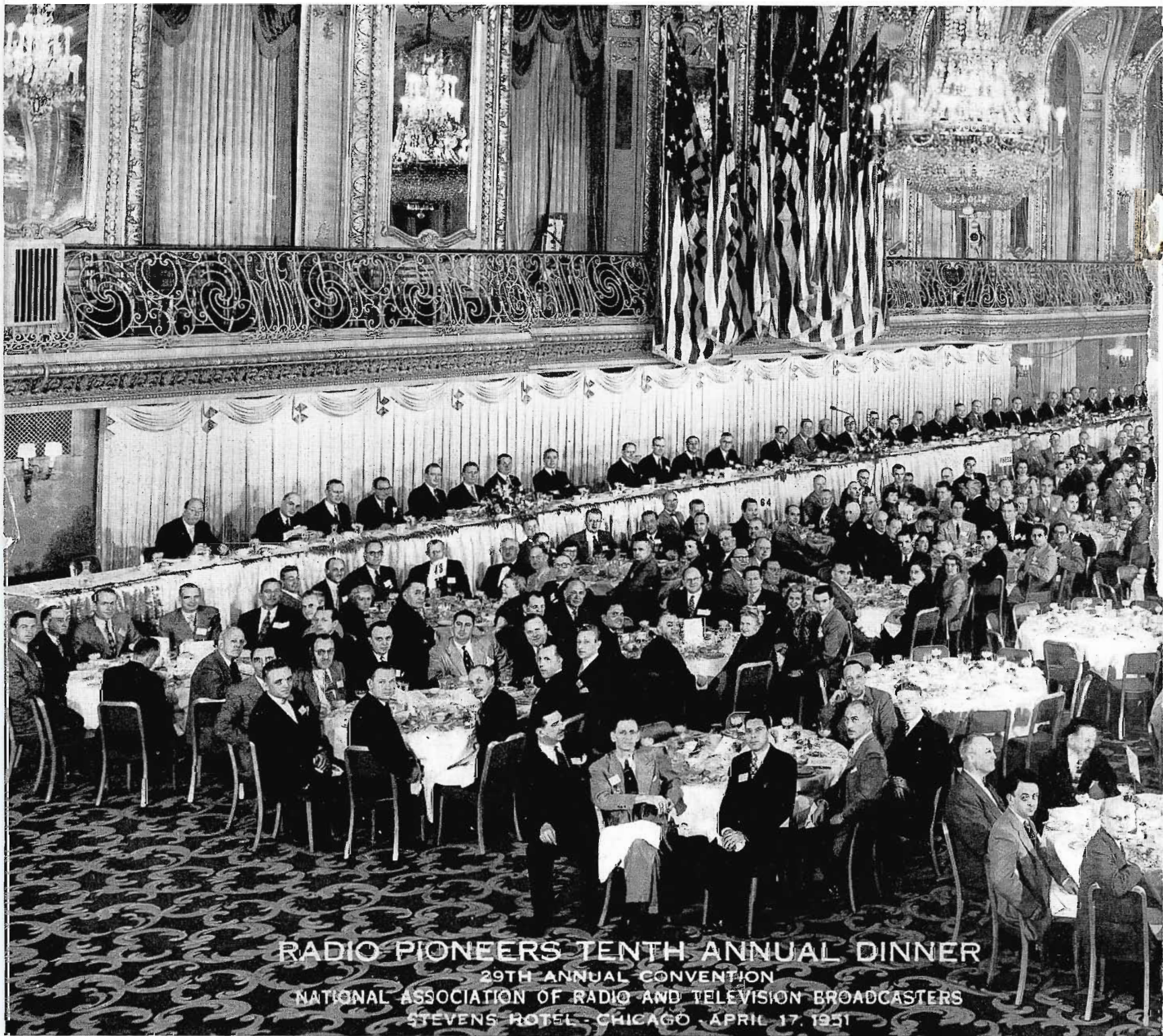

FIG. 8 (at right below). Comparison of pickups of different types and construction. Curve "D" was obtained with the RCA MI-11874 pickup.





RADIO PIONEERS DINNER

NEW FEATURE OF

NARTB CONVENTION

The photograph above was made during the Radio Pioneers Club Banquet which was held in the ballroom of the Stevens on the second evening of the recent NARTB Convention. One of several innovations at this year's convention, the banquet was well-attended and quite likely will become a regular feature of future conventions.

High lights of the banquet program were the ceremony attending the selection of Guglielmo Marconi to the Radio Hall of



Fame and the main address of the evening by Senator Estes Kefauver.

The citation honoring the memory of Marconi was presented by Edgar Kobak and accepted in Marconi's name by Orrin E. Dunlap, Vice President of RCA, famed chronicler of radio's outstanding men and their achievements. Mr. Dunlap, a personal friend of the Marconi family, introduced to the assembled audience Mrs. Degna Paresce, daughter of the great inventor, and one of the honored guests of the evening.

Senator Kefauver, fresh from his starring role in the televising of the Senate Crime Investigation Committee's hearings, stressed the important role which television will play in arousing the public to the dangers of organized crime.

The Radio Pioneers Club, founded ten years ago by H. V. Kaltborn, holds just one meeting a year—its annual banquet. The "business" of the Club, which consisted of reports by committee chairmen and election of new officers, was conducted

by the chairman while the membership dined. Needless to say, there were no objections from the floor, and a new slate of officers was chosen with astounding despatch. New President is Carl Haverlin of BMI. First Vice President is Jack Poppele of WOR. Also elected Vice Presidents were Paul Morency, WTIC; Arthur Church, KMBC; Ray Guy, NBC; and O. H. Caldwell, TELE-TECH. Sydney Kaye, BMI, was elected Secretary, and Herb Akerberg, CBS, Treasurer.

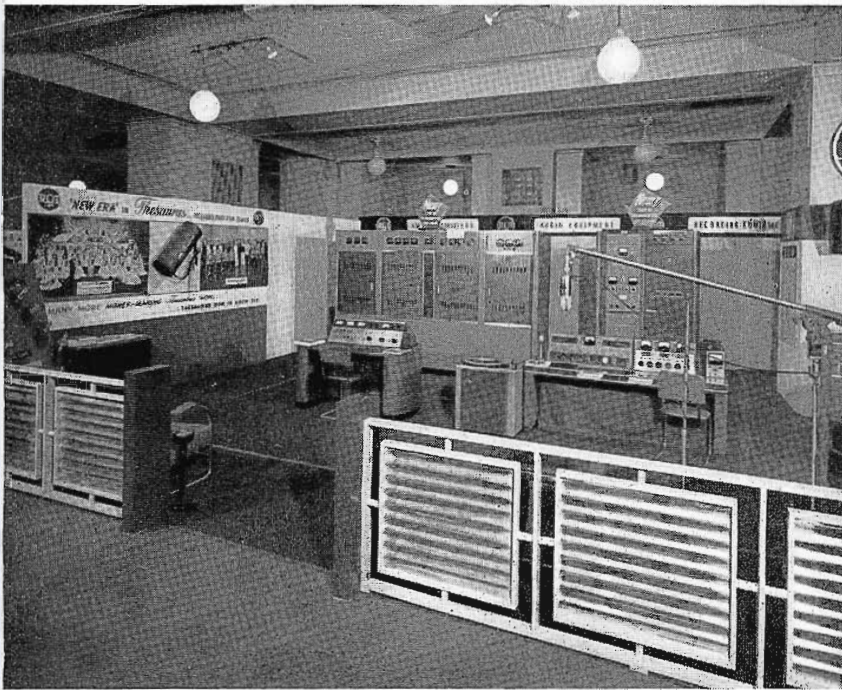

THE LEFT WING of the RCA display was devoted to AM Transmitters, Audio and Tape Recording equipment. New items included 5-kw and 250-watt AM Transmitters, and two new Studio Consolettes.

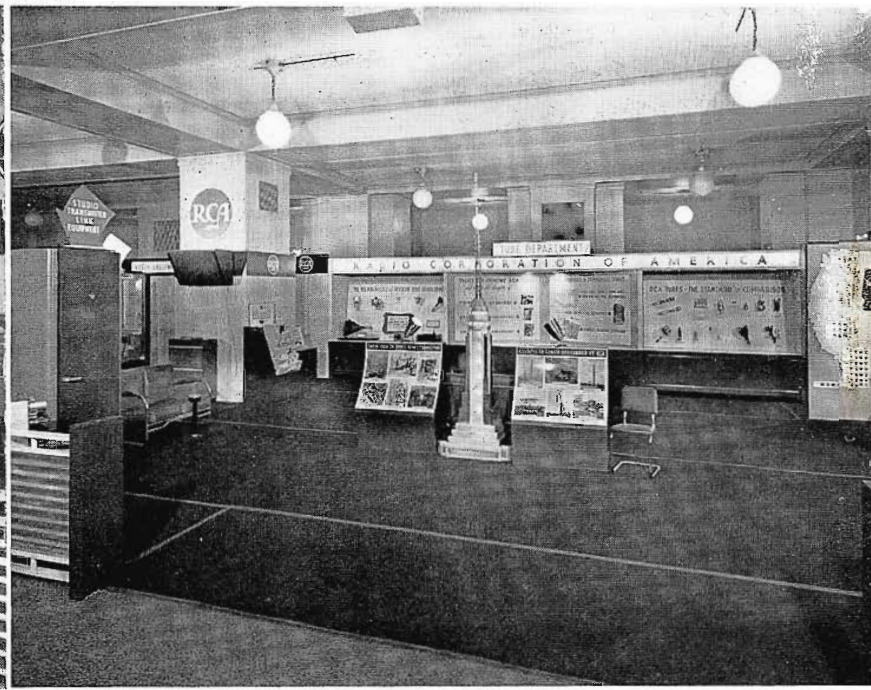

LEFT CENTER PORTION of the booth included the RCA Tube display, a replica of the Empire State Antenna and a flasher-illuminated map showing equipment used by TV stations.

BELOW: Looking down the entire 125 feet of RCA NARTB display space. One main unobstructed center aisle was provided in the booth plus another smaller aisle behind the four-foot columns.





RIGHT CENTER PART of the display was devoted to a wide variety of TV studio equipment including a working setup to demonstrate the Genlock, Special Effects and the Flying Spot Camera, as well as a "Custom" TV/Audio Console.



THE RIGHT WING of the booth was devoted exclusively to "TV". Displays included the new 2-kw TV Transmitter, new 20-kw TV Amplifier, plus 500-watt Transmitter and several complete TV station model layouts.

RCA's LARGEST NARTB SHOW FEATURES NEW VHF TV EQUIPMENT

New VHF Television Transmitter Equipment received "top" attention from broadcasters visiting RCA's extensive exhibit at NARTB in April. With nearly 2000 station owners, managers, and engineers in attendance, TV planning (both present and future) was the main topic of conversation. The RCA exhibit with its new 2-kw and 20-kw Television equipments proved to be the outstanding attraction.

The overall RCA equipment display at this year's convention dominated the exhibition hall. Occupying 3750 square feet of floor area, it was the largest and most comprehensive single broadcast exhibit ever attempted by RCA—and probably the largest ever attempted in the broadcast industry. The display included, in addition to the new television transmitters, new AM transmitters, new audio equipment, studio consoles, TV studio equipment and several complete television station model layouts.

The new 2-kw TV transmitter and 20-kw TV amplifier were shown as additions to the RCA line which already includes 500-

By
W. O. HADLOCK
Engineering Products Department

watt and 5-kw models. The new VHF TV transmitters meet proposed new FCC allocations designed to open TV service in almost every American community. For broadcasters wishing to increase the power output of a 5-kw TV station, the 20-kw TV amplifier was of prime interest. Transmitter-antenna combinations available offered a wide range of power output to 200 kilowatts.

Also unveiled in the RCA exhibit, were new AM transmitters, studio consoles and new audio equipment. The new AM and TV transmitters shown featured lower power consumption, smaller space requirements, and centralized controls. Fewer tubes, r-f stages, and components are also among the trends noted in both the 250-watt and 5-kilowatt AM models. The new 5-kw AM transmitter is designed for alternate 10-kw operation with only a few minor modifications.

One of the most interesting items to be shown by RCA was a studio console planned for operating convenience and ease of servicing. A new master switching console styled to match the studio console makes possible a convenient, central master-studio control, utilizing existing studio consoles, and permitting an economical desk-top installation. Microphones, loudspeakers, turntables, tape recording equipment, and a new limiting amplifier were also among this year's audio offerings in the RCA exhibit.

In addition to other equipment, RCA displayed a wide variety of television studio equipments, including the "Genlock," special video effects and flying spot scanner equipment, utility monitors, and the new modified PG-400 Projector. Other displays of special interest were the custom built console designed by RCA for NBC's new TV studios in the Center Theatre, in New York City, and a replica of the Empire State Building tower with its new RCA multiple-antenna array, designed to serve as the focal telecasting point for most of Manhattan's TV stations.

(Cont. next page, see "Planning Headquarters")



This view of the RCA space which was taken near the main entrance shows the activity in the center aisle. Visible in background is studio equipment flanked by transmission line displays.



A view of part of the RCA space looking down the main aisle. Just visible at far end is the "This is it" display of the 20-kw TV Amplifier.

Photo of another part of the RCA space showing the center aisle activity. Barely visible at far end is Empire State Antenna model and RCA Tape Recorder. At the right the Custom TV/Audio Console is plainly visible.



RCA EXHIBIT IS "PLANNING HEADQUARTERS"

Just as in past years, RCA's NARTB exhibit served as a central "meeting place" and the focal point of Broadcast Station Equipment Planning. With plenty of space and numerous lounges and chairs available, the RCA display area served as a comfortable, convenient setup where our customers and prospects could relax, renew old acquaintances, and "iron out" their equipment problems.

With representatives of RCA's Sales, Product and Engineering Groups in attendance at all times, broadcasters had the opportunity to learn about the newest developments in broadcast equipment and discuss their plans for getting "on-the-air." Moreover, the preponderance of actual equipment and operating type displays made it possible for broadcasters to personally examine new equipment and in many instances operate it themselves.

Shown on the following pages are a few of our broadcast customers, prospects and sales representatives photographed at the RCA exhibit.

Left to right: Mr. James L. Middlebrooks, Chief Facilities Engineer, American Broadcasting Company; Mr. Frank Marx, Vice President and Chief Engineer of American Broadcasting Company; Ventura Montez, Chief Engineer, CMQ, Havana, Cuba; and Al Josephsen, Mgr., RCA Broadcast Network Sales, in front of 20-kw TV Amplifier.





Charles E. Salik (right), President, Radio Station KCBQ, San Diego, California, with Jack Frost, RCA Hollywood Sales Representative, in front of 20-kw Amplifier.

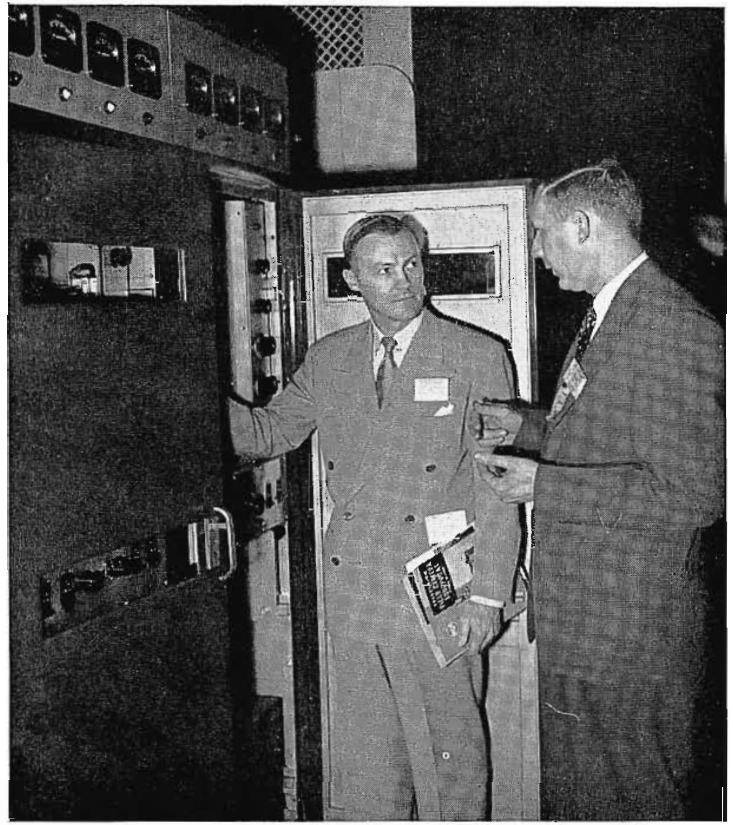

Austin A. Harrison (left), President and General Manager, KSWM, Joplin, Missouri, and Walt Varnum, RCA Sales Representative, Kansas City, examine new 2-kw TV Transmitter.

Mr. Jorge Edo (right), Chief Studio Engineer, PRF3-TV, Sao Paulo, Brazil and Cliff Slaybaugh, Manager Broadcast and TV Sales, RCA International, inspect Empire State Antenna model.

W. A. Smith (left), Chief Engineer, WROK, Rockford, Illinois, and J. L. Nickels, RCA Sales Representative, Chicago, discussing new BC-2B Audio Consolette.

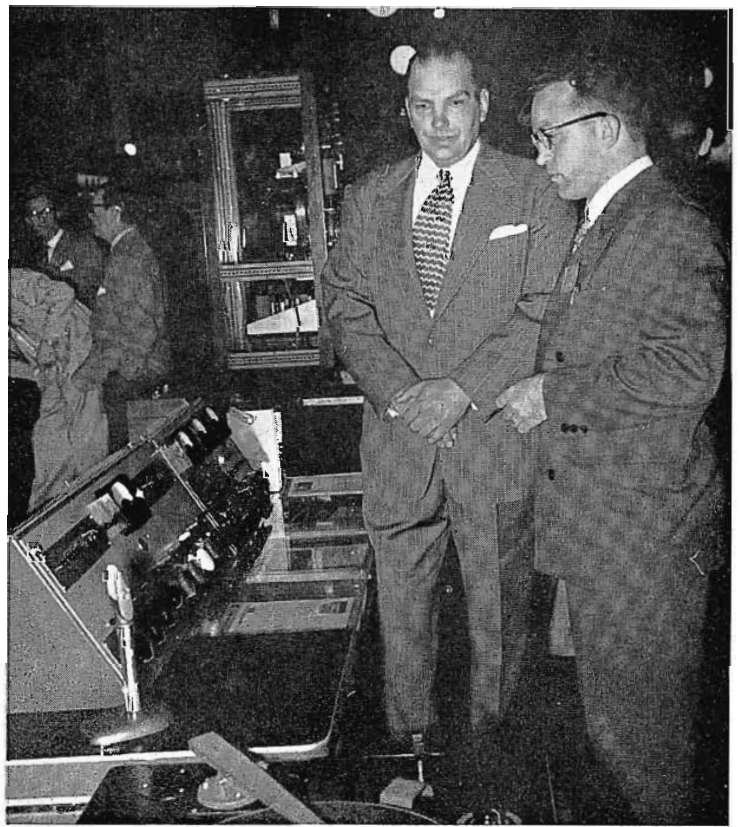



(Right to left), J. A. Engelbrecht, President and General Manager WIKY, Evansville, Indiana, and J. W. Hillegas, RCA Sales Representative, Atlanta, look over new BC-2B Console.



E. C. Frase, Jr. (right), Chief Engineer of WMC, WMCF and WMCT, Memphis, Tennessee, discusses features of 2-kw TV Transmitter with P. G. Walters, RCA Sales Representative, Atlanta.

Max E. Pierce (left), Chief Engineer, KSOO, Sioux Falls, South Dakota, and R. J. Newman, RCA Product Manager, Broadcast Transmitter Equipment, inspect the new 5-kw AM Transmitter sold to KSOO.

Joe Conn (right), Chief Engineer of KTTV, Los Angeles, California, and Jack Frost, RCA Sales Representative (Hollywood), inspect 20-kw Amplifier.

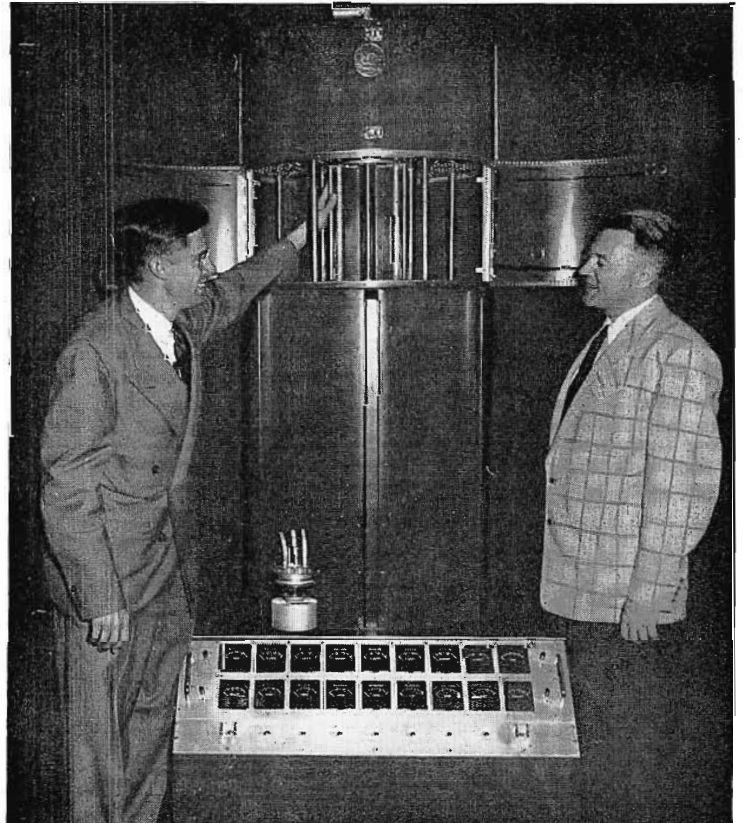



(Above). (Standing left to right) Norman L. Hobson, RCA, TV Engineer; B. B. Barnes, Chief Engineer, WAPO, Chattanooga, Tennessee; and J. Wesley Koch, Chief Engineer of KFEQ, St. Josephs, Missouri. Seated at the Custom Audio/Video Console are (left to right) L. E. Anderson, RCA TV Engineer, and Russell P. Williams of WWJ-TV, Detroit, Michigan.

(Below). Harry E. Huffman (right), President of KLZ, Denver, Colorado, with E. C. Clammer, RCA Sales Representative, Camden, New Jersey.

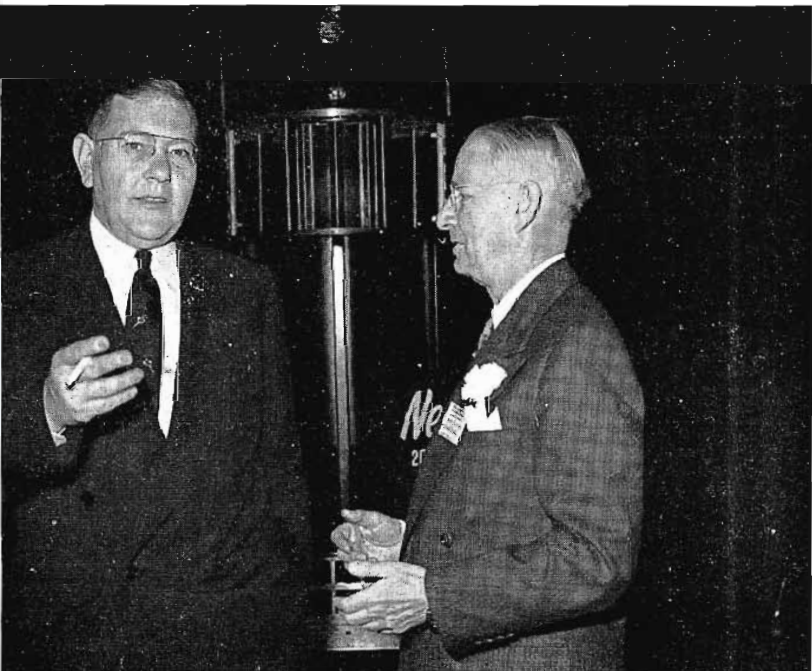

(Below). (Left to right) Wally Poch, Manager of RCA TV Terminal Engineering; Louie Lewis, Chief Engineer of WOI-TV, Ames, Iowa; and Norm Kellaway, RCA TV Engineer, inspect new "Electra-Zoom" lens.



(Above). (Left to right) C. N. Layne, General Manager, KID, Idaho Falls, Idaho; Harold J. Newcomb, Station Manager, WRJN, Racine, Wisconsin; and E. C. Tracy, Manager of RCA Broadcast Equipment Sales, discussing operation of Flying Spot Camera.

(Below). R. J. Schroeder (left), Chief Engineer of KMTV, Omaha, Nebraska, discusses new BC-2B Console with David Bain, Product Manager of Broadcast Audio Equipment.



(Below). V. A. Vanderhieden (left), Chief Engineer, Radio Station WKOW, Madison, Wisconsin, looking over 20-kw TV Amplifier with J. L. Nickels, RCA Sales Representative, Chicago.





(Above). W. P. Williamson (left), President and General Manager of WKBN, Youngstown, Ohio, discusses equipment problems with David Newborg, RCA Cleveland Sales Representative.



(Above). Ernest L. Adams and Richard E. Lauth (at left), of WHIO-TV, Dayton, Ohio, operate the video switching relays with Henry Duszak, Product Manager, Broadcast Video Equipment.

(Below). (Right to left) Al Josephsen, RCA Network Sales Representative, New York City; George R. Cook of WLS, Chicago, Illinois; and W. O. Hadlock of RCA Broadcast Advertising, looking over "Electra-Zoom" lens.

(Below). Philip K. Baldwin (at right), Chief Engineer, Radio Station WHDH, Boston, Mass., looking over 20-kw Amplifier tubes with J. E. Hill, RCA New England Representative.



(Below). Harold J. Newcomb (at left), Station Manager of WRJN, Racine, Wisconsin, discussing Flying Spot Camera with E. C. Tracy, Manager of Broadcast Equipment Sales.



(Below). E. C. Frase, Jr. (left), Chief Engineer of WMC, WMCF and WMCT, Memphis, Tennessee, studying equipment data with John Palmquist, RCA Dallas Sales Representative.



THE REQUIREMENTS OF TELEVISION STATION DESIGN

By DR. WALTER J. DUSCHINSKY*

PART IV

Physical Arrangement of An Ideal TV Studio

As the planner sees it, the form of a TV station is dictated largely by its function. Having once developed a master plan on the basis of function, it is possible to group station areas—production, technical and administrative—into the pattern best suited to operational requirements. To be sure, some limitations will be imposed by the building site and others by the state of technological arts; but aside from these,

.....
EDITOR'S NOTE: This is the fourth of a series of articles written especially for BROADCAST NEWS by Dr. Duschinsky, well-known consultant on TV Station Planning. The first three articles appeared in the preceding three issues of BROADCAST NEWS.

it must be expected that the planned TV station of the (near) future will develop its own form. This is only natural, for television is different from other media of communications and entertainment. Its unique qualities demand other than conventional designs carried over from older, more familiar types of installations.

Take a hypothetical example of a planned TV station. It is of an originating type, but also coupled with a network. At the beginning of operations, it intends to produce a limited number of live-talent shows and to relay tele-film programs. A mobile unit supplies both indoor and outdoor telecasting from the field. In addition, several live-talent shows and mobile-unit station telecasts are to be recorded for transmission as delayed programs. Finally, the station's tele-cine unit will produce short commercials.

The administrative staff consists of a full complement—including executive personnel, a sales department, a publicity and public relations office, an accounting office, and the usual clerical personnel.

As the illustrations accompanying this article show, such a station is planned in terms of its functional units. Today's limiting factors—the control equipment and its installation area, the light bridge and its equipment—are treated not as fixed but as loose elements "floating" over the studio area. In such a conception, the studio area itself is used only for the movement of cameras and scenery, for actors and the necessary operational personnel.

This functional studio will be of larger dimensions than its present-day counterpart. It will be at least two stories high

* 425 E. Fifty-third Street, New York 22, N. Y.

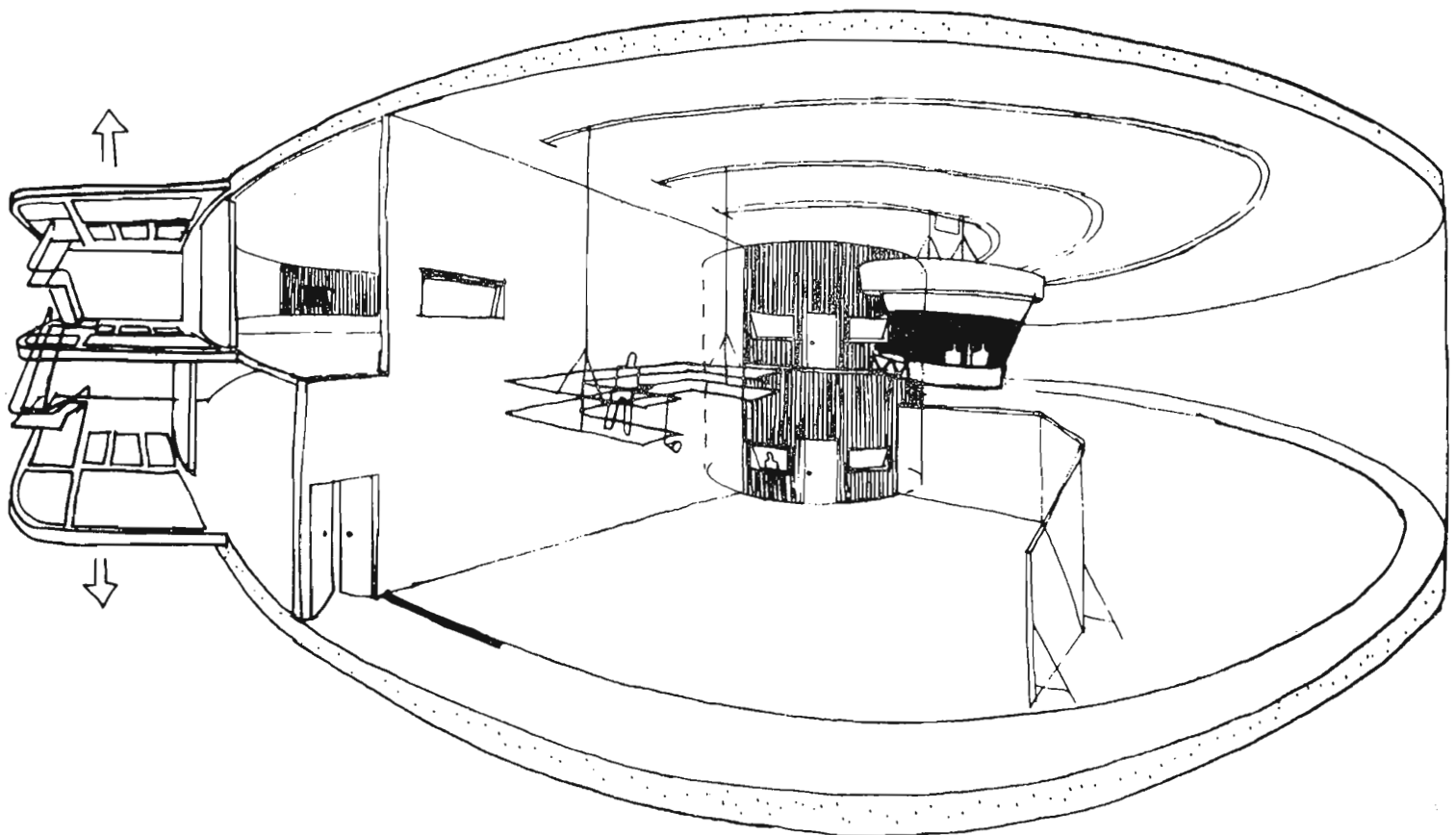

FUNCTIONALLY DESIGNED STUDIO OF A WELL-PLANNED TV STATION

ARRANGEMENT OF CABLES IN A FUNCTIONALLY DESIGNED TV STUDIO

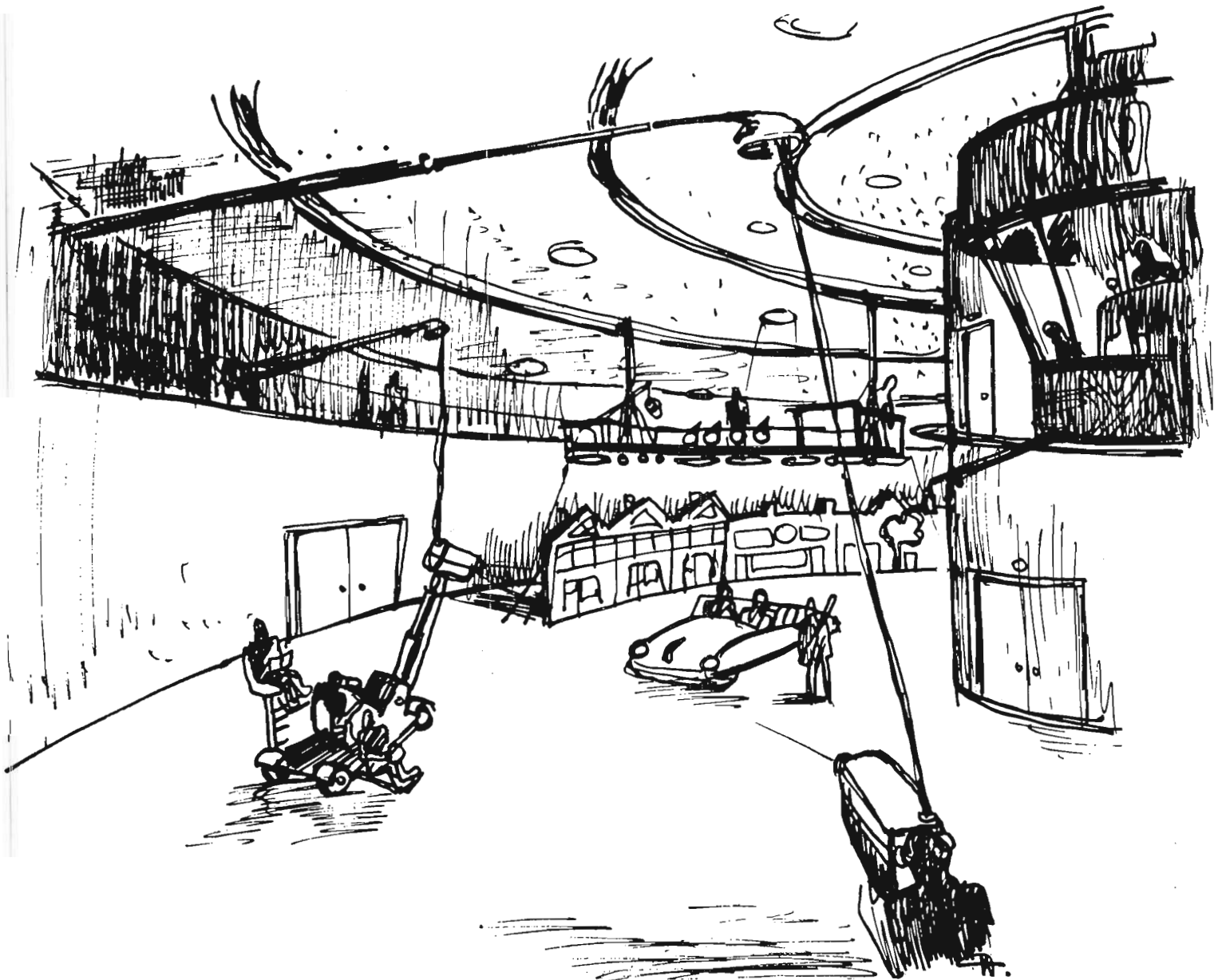

and will carry in its ceiling a series of overhead tracks. On one track will be a circular movable control booth with all necessary control equipment. Two other tracks will hold a U-shaped light bridge, its equipment and crew. Control booth and light bridge will move along the tracks to any section over the studio floor, as production needs demand.

The actual production area can be separated from the rest of the studio floor by flexible, transportable screens adapted to acoustical conditions. Sound will be controlled from the overhead booth, which may have a remote-control boom-microphone attached to it. Similarly, other such microphones can be carried by the light bridge.

While the production process goes on in the studio area under the direction of the production supervisor, the control booth moving along its ceiling track can take any desired position. If it is necessary to expand the shooting area for any given program, planned design has met this nowadays impossible situation.

Cameras will still be employed mainly on the studio floor, but auxiliary cameras for special or "trick" shots can be located in the surrounding gallery or supported from the ceiling tracks. That major nuisance, the feeding of cameras by floor cable, can be eliminated—perhaps by a movable feeding-funnel which supplies cable to its camera from the gallery or ceiling. If supported from the gallery, this

funnel feed might be fixed to a telescoping, swinging arm. And in the wake of these improvements, camera dollies can be redesigned for automatic rather than manual operation.

Today's usual telephonic cable connections for intercommunication between operational personnel and control would be supplanted by a radiation multi-channel system. Actors would receive their cues from screen-reproduced facsimile or from specially designed radio cueing devices.

A further efficiency of the circular studio stems from the use of segmented areas for complementary production activities. Scenery and props can be stored at floor level while a higher level can be devoted to dressing rooms, wardrobe and auxiliary

T.V. ORIGINATING STATION DESIGNED SCHEMATICALLY FOR VERTICAL DEVELOPMENT IN COMPOSED UNIT FORM.

- 1 STUDIO FLOOR
- 2 OUTER CIRCULATION
- 3 SCENERY STORAGE
- 4 CORE VER. TRANSP.
- 5 TECH. CONTROL A.
- 6 NON. TECH. TRANSP.

KEY:

- 7. PROP. STORAGE
- 1'. UPPER PART ST.
- 2'. LIGHT & TECH. A.
- 4'. INTERA. CORE
- 5'. TECH. CONTROL A.
- 6'. NON. TECH. TRANSP.
- 14. CON. CORRIDOR
- 15. T.V. CONTROL BOOTH CIL. TRACK.
- 16. LIGHT BRIDGE TRACK.
- 17. CONTROL BOOTH.
- 18. LIGHT BRIDGE
- 19. ATTACHED FLOOR AREA.

- 8. MAIN REHEARSAL AREA
- 9. OBSERV. BOOTH AREA
- 10. M. DRESS. R/M'S & LAV.
- 11. V. DRESS. R/M'S & LAV.
- 12. STAR DRESS R/M'S
- 13. MAKE UP R/M'S

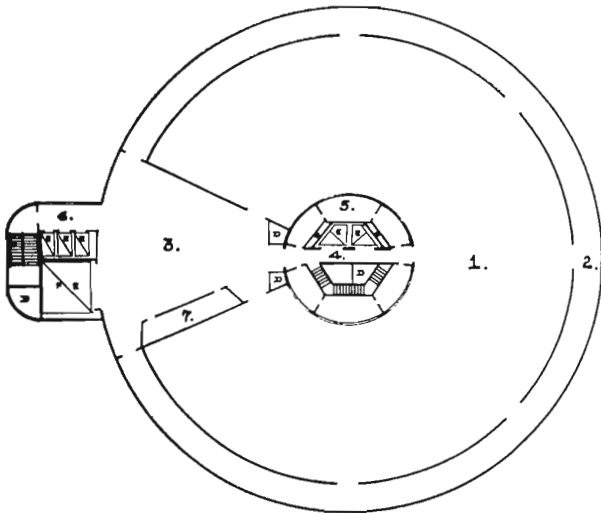

TYPICAL T.V. STUDIO FLOOR PLAN.

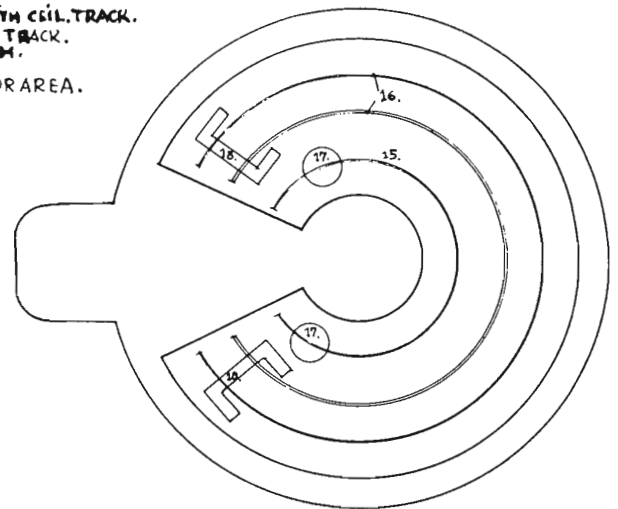

TYPICAL CEILING PLAN FOR T.V. STUDIO.

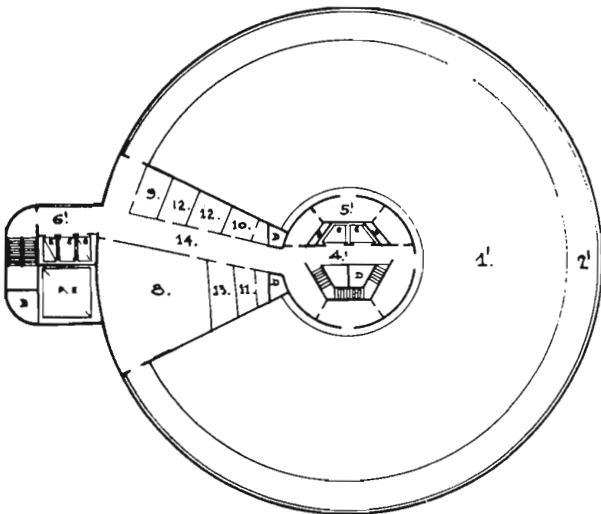

TYPICAL T.V. INTERMEDIATE LEVEL STUDIO FL. PL.

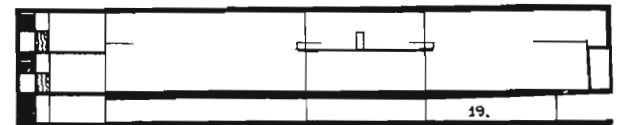

COMPOSED SECTION-ELEVATION VIEW OF ONE S. UNIT OF T.V. STUDIO BLDG.

Walter D. ...
New York, Oct 1949.

facilities. Moreover, observation windows on the upper level can look down on the studio floor.

All of the foregoing are necessary to the planning and execution of a well-designed studio. But a carefully conceived plan must also consider the possibilities that an originating station will, at some future time, wish to expand its programming. Besides, some provision should be made for new but foreseeable technological change. Thus, with the coming of color

television, questions will inevitably be raised about video color characteristics, and how their employment differs from black-and-white production. And indications are that at least one special "color-equipped" studio will be required.

Then too, the planner should allow for the future operational integration of well-located or mobile background-projection equipment capable of projecting images on large, well-lighted screens. Immediately or in the future, as the station produces

complex programs, it will probably need a stage turntable and a stage elevator. Therefore, the planner must reserve space in certain studio areas for heavy mechanical and electronic equipment which will eventually play an important role in production.

This, then, is the physical arrangement of a thoroughly planned TV studio. It has numerous noteworthy features.

One of these is the separation of technical traffic (operational, production and

MAIN TRAFFIC FLOW PATTERN DIAGRAMMATICALLY SHOWN
FOR VERTICAL DEVELOPMENT IN COMPOSED UNIT FORM,
OF T.V. ORIG. STATION.

KEY TO MAIN TRAFFIC PATTERN:

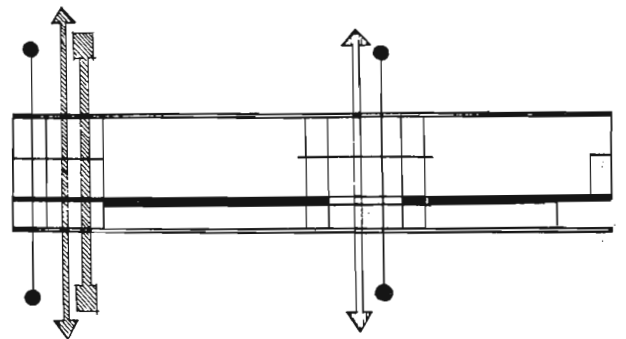
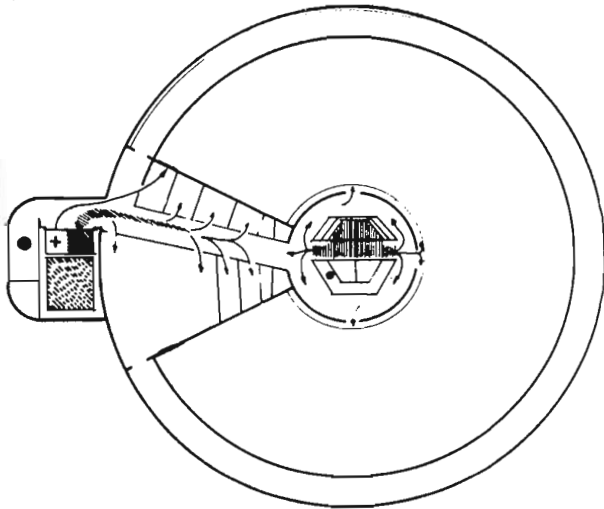
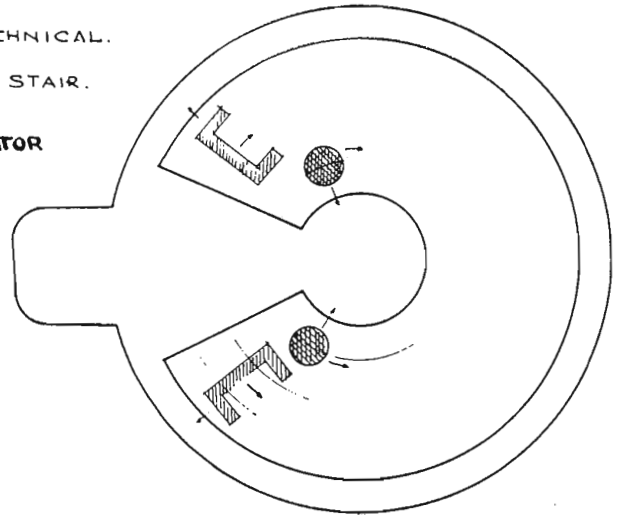
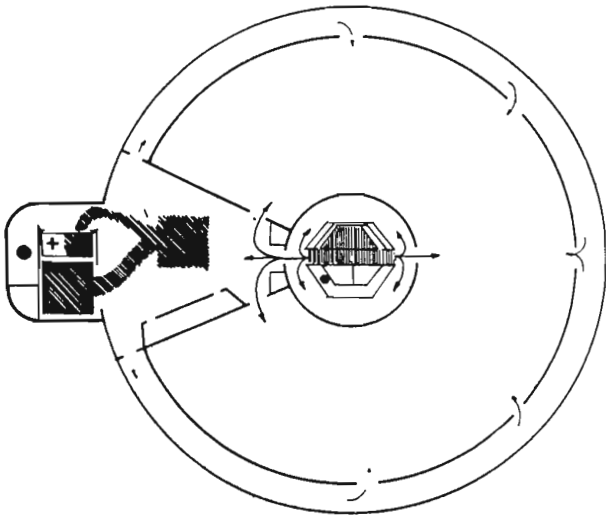
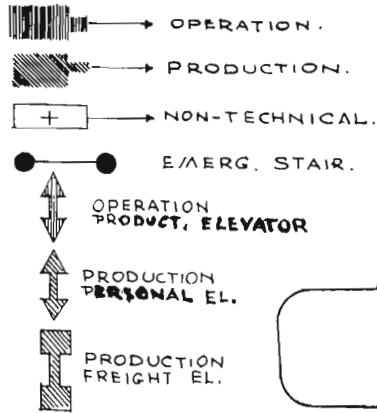

*Walter...
N.Y. 22.*

maintenance) from the traffic flow patterns of program artists. Traffic congestion and confusion, which in present-day studios are attributable to improper layout, are totally eliminated.

In the arrangement suggested here, a central core inside the circular studio area provides vertical transportation and an emergency staircase for technical personnel who work in the core. Built into the outer ring of the central core, on both levels,

are recording rooms, sub-master control rooms and observation booths. In sum, the core has its own horizontal and vertical traffic patterns which are undisturbed by other station personnel.

Meanwhile, around the outside of the circular studio area, there runs a wide surrounding corridor for the movement of scenery, props and heavy equipment. At the upper level, the corridor becomes an open gallery, looking into the studio.

A wide segment of the studio floor serves a double purpose as production storage and as a connection between the center core and the circumferential corridor. At its outer end is a vertical transportation tower, with freight and passenger elevators stopping only at levels assigned to them. These are used for equipment on the one hand and production personnel on the other. The tower, therefore, provides not only convenient transportation; it also segregates the traffic of artists, performers

VERTICAL DEVELOPMENT OF A TV ORIGINATING STATION
 ACCOMPLISHED BY "STACKING" OF STUDIOS OF COMPOSED UNIT FORM

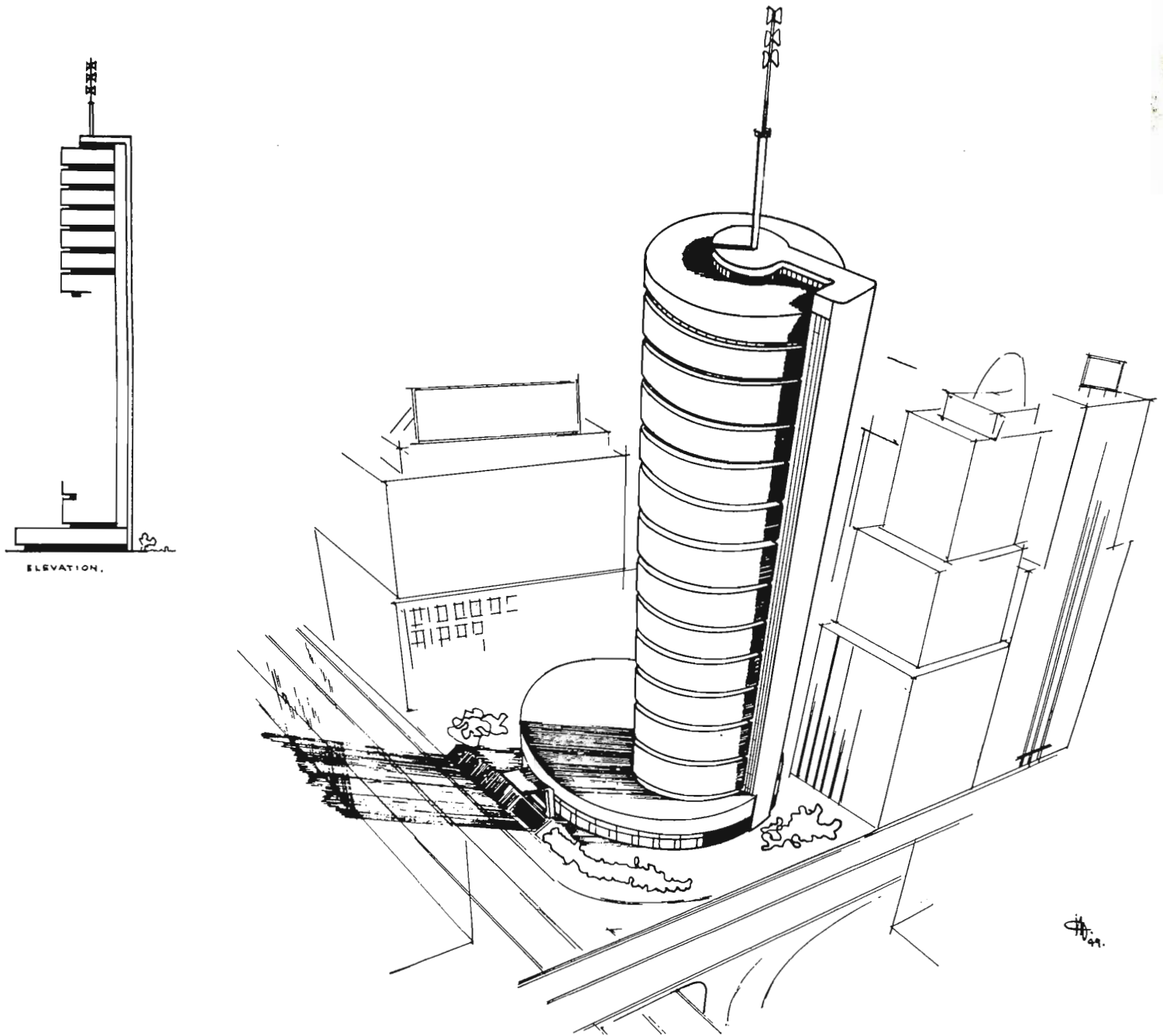

and studio crews from the traffic of operational personnel in the center core.

Finally, in the circular truss floor are housed the offices of the production, technical and administrative staffs. With these, the three levels (two for studio production and one for general use) form a self-sufficient studio unit. They accommodate all the administrative, production, operational and maintenance areas required for an originating station. And, what is vital, because of its truss-floor construction, this unit allows for contiguous expansion—in a vertical direction.

As these units multiply upward, certain

corrections, additions and modifications will obviously take place in order to insure that the enlarged station operates as a functional whole. But this plan will demand fewer alterations than occur, say, when one of today's stations takes over a theater or remodels a loft building.

The core always remains the station's nerve center—containing all technical personnel, the technical control areas, and all ducts and trenches for electrical and mechanical equipment, including a separate air-conditioning system. The outside tower will always carry all production traffic and contain the duct system and air-

conditioning for studios and auxiliary areas. Two shafts running vertically through the segmented production-storage area will always accommodate utilities.

This is the complete though somewhat simplified plan of a functional television station. At first glance, it may seem radical in contrast to our current unplanned studios. Actually, it is not. The basic elements of today's facilities are still here. The only difference is: they have been rearranged to bring a maximum of efficiency, economy and flexibility to the three aspects of station ownership—production, operation, and maintenance.

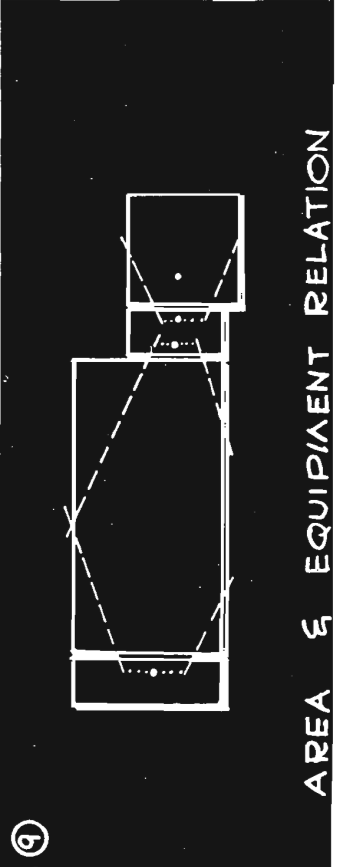
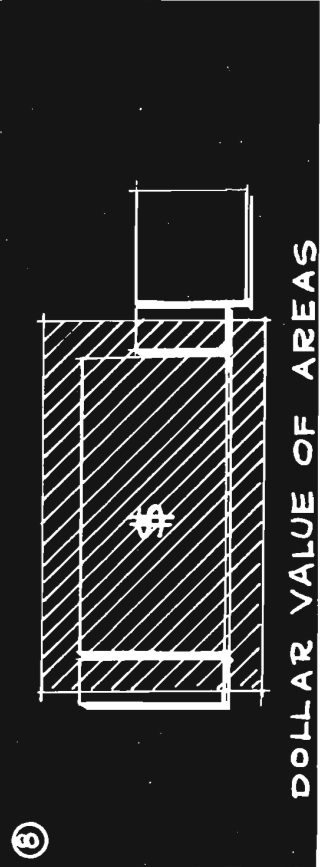
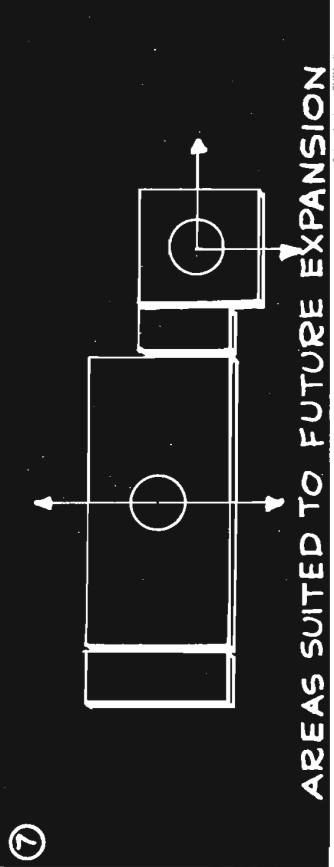
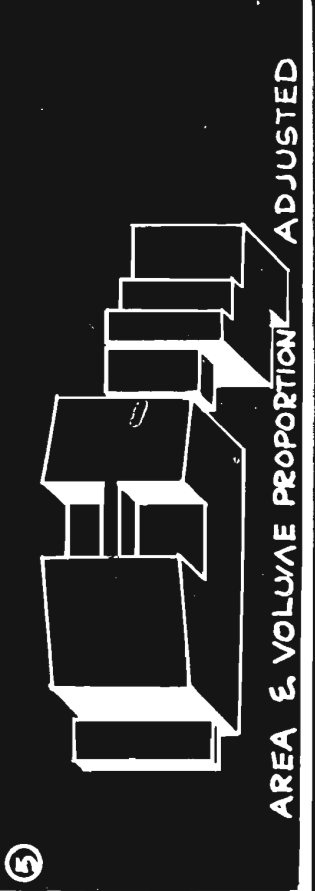
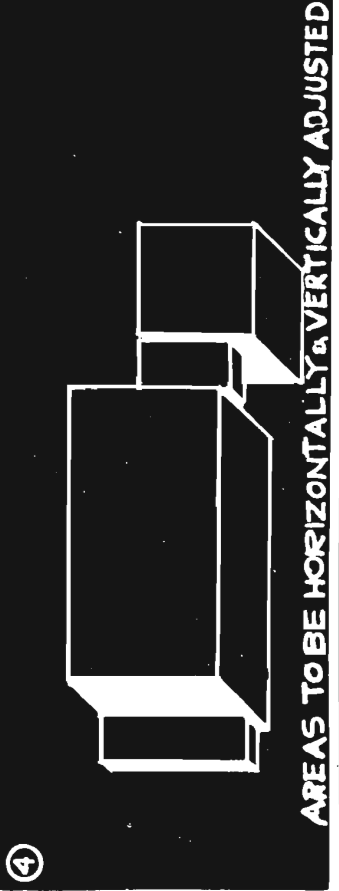
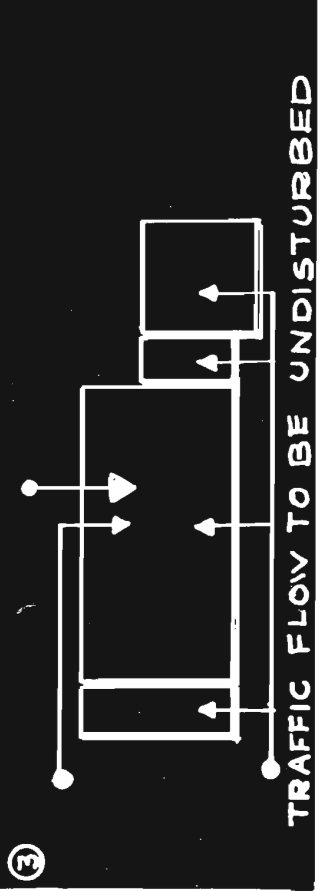
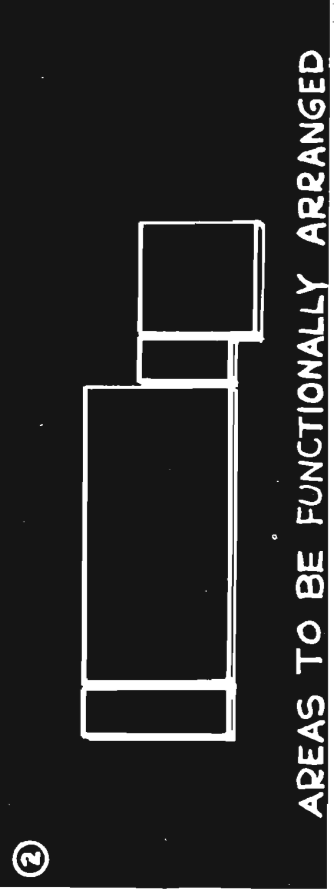
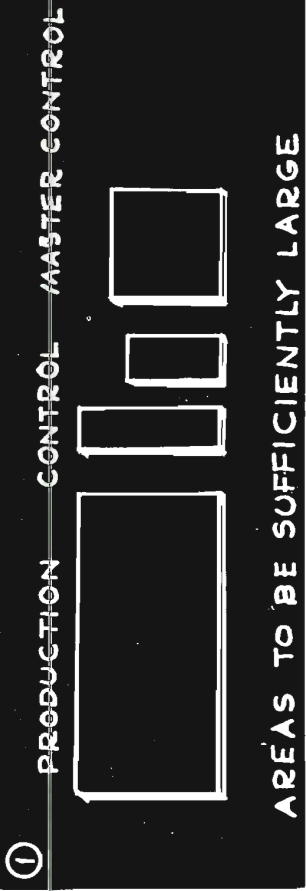

**THE CREATION
OF
A FUNCTIONAL AREA CHAIN
IN T.V. STATION**



FIG. 1 (at left). The 450-foot TV-FM antenna and tower is the only outward sign of the transition of the fabulous Sutro Mansion into the ultra-modern home of KGO-TV.

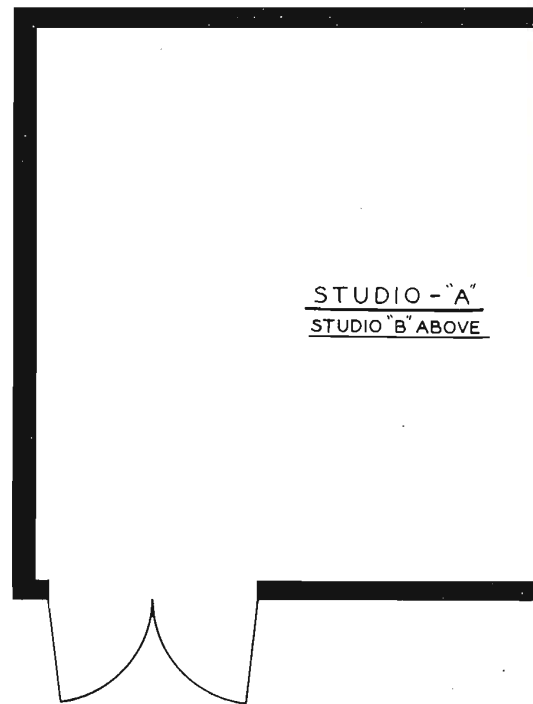

KGO-TV, SAN FRANCISCO

Introduction

Strange things have happened to San Francisco's secluded and fabulous landmark, the Sutro Mansion, perched high atop Mount Sutro overlooking the equally fabulous and colorful city of San Francisco. Here, amid the dense forest of eucalyptus trees where the grandson of San Francisco's pioneer mayor formerly sought extreme privacy, there has evolved the electronic trappings of an ultra-modern television station.

This isolated, yet impressive, French Provincial structure is the home of KGO-TV,

by the KGO-TV Engineering Staff

the American Broadcasting Company's television station for the San Francisco-Oakland Bay Area. Operating on channel 7, KGO-TV began telecasting May 5, 1949.

The how and why of ABC's selection of the Sutro site for its television operations in this region dates back to September, 1946, when KGO Engineering Manager, A. E. "Shorty" Evans, cast a professional eye on the property and suggested consideration of its purchase to ABC officials in New York. After consulting engi-

neers had run several engineering and transmission tests from the mansion, there was no question about the excellence of the location for a television tower and transmitter.

Not only was the location good because of its height, but the solidly-built French Provincial mansion itself, erected in 1932 under the personal direction of Adolph Sutro III—a construction perfectionist, offered readymade studio and office space readily accessible to downtown San Francisco. The ground floor of the three-story structure has an area of 15,000 square feet

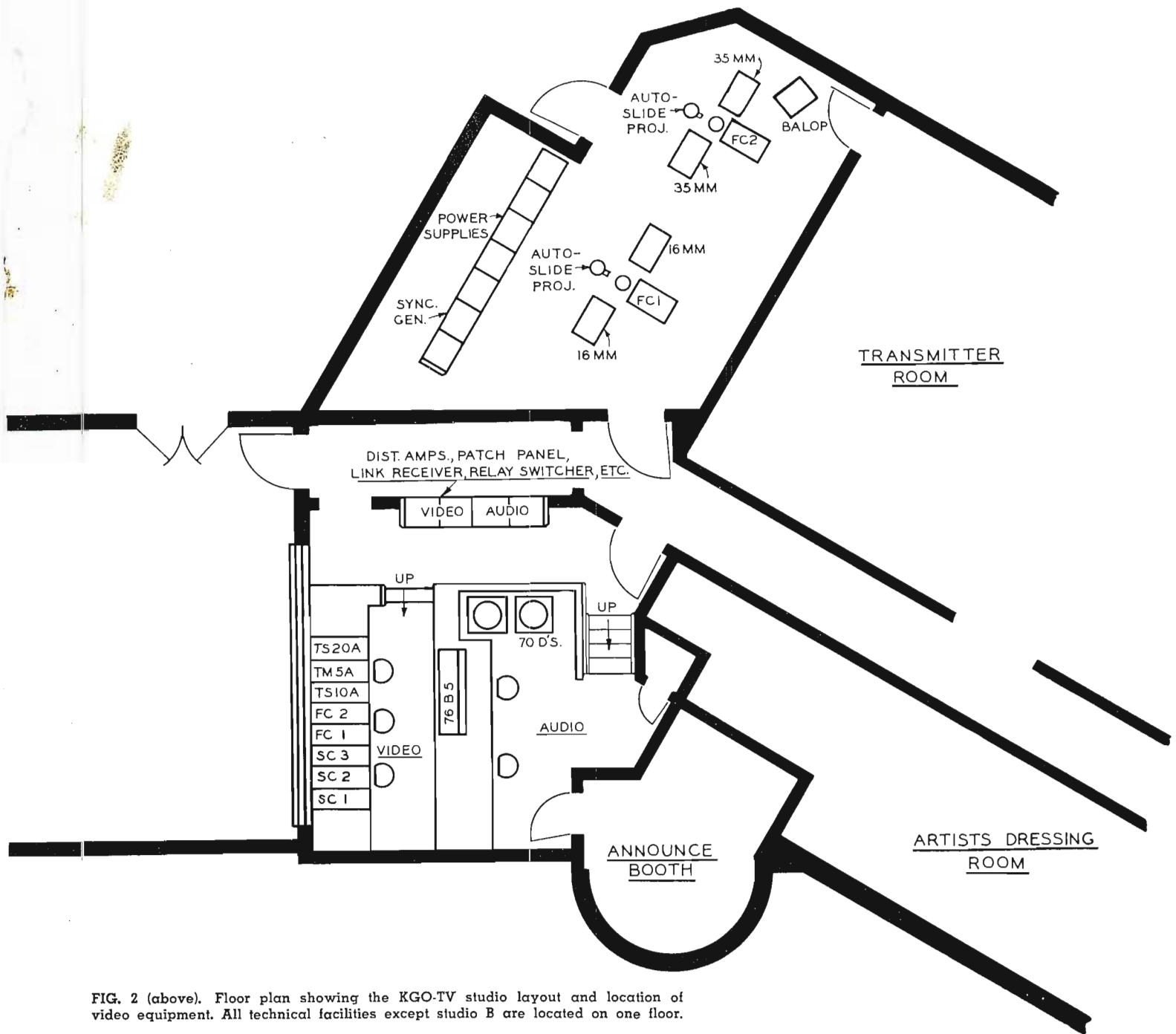

FIG. 2 (above). Floor plan showing the KGO-TV studio layout and location of video equipment. All technical facilities except studio B are located on one floor.

with no supporting pillars—an ideal arrangement for incorporation of studio and transmission facilities.

When ABC Board Chairman, Edward J. Noble, saw his fieldmen's report, he signalled the green light on the transaction, and Evans—one of the few with whom Adolph Sutro III would talk business—began what turned out to be long months of direct negotiations for the purchase of the property. Finally, on November 29, 1947, the deal was closed, and for \$102,500 ABC bought the mansion and its surrounding six acres of grounds. On behalf of ABC, Gayle V. Grubb—general manager of KGO

—took formal possession of the property on Friday, August 13, 1948. Having been granted its original construction permit on March 9, 1947, KGO-TV began actual construction in September, 1948, under the supervision of J. L. Middlebrooks, ABC New York; Mr. Evans; H. N. Jacobs, Station Engineer; and M. C. Jones, Maintenance Supervisor.

Studio Building and Facilities

The only changes in the 16-year-old hybrid French Provincial structure were made in the basement, which consisted of a single large room used as a combination shop, storeroom and garage. The 15,000

square feet provided ample room to allow proper studio space in the existent structure. Here was constructed Studio A, the TV control room which overlooks the studio, a film and slide projection room, the KGO-TV and KGO-FM transmitters, dressing rooms, as well as workshops, garage and storage space.

The upper floors have remained basically unchanged. The dining room became the main lobby and reception room of the new television center. From this room spacious French doors open on to the flagstone path and overlook the stately eucalyptus forest and the hills of Oakland and

FIG. 3. Looking out on studio A. KGO-TV's control room A is built on two levels—the lower for video and the upper for audio—giving all personnel an unobstructed view of the studio.

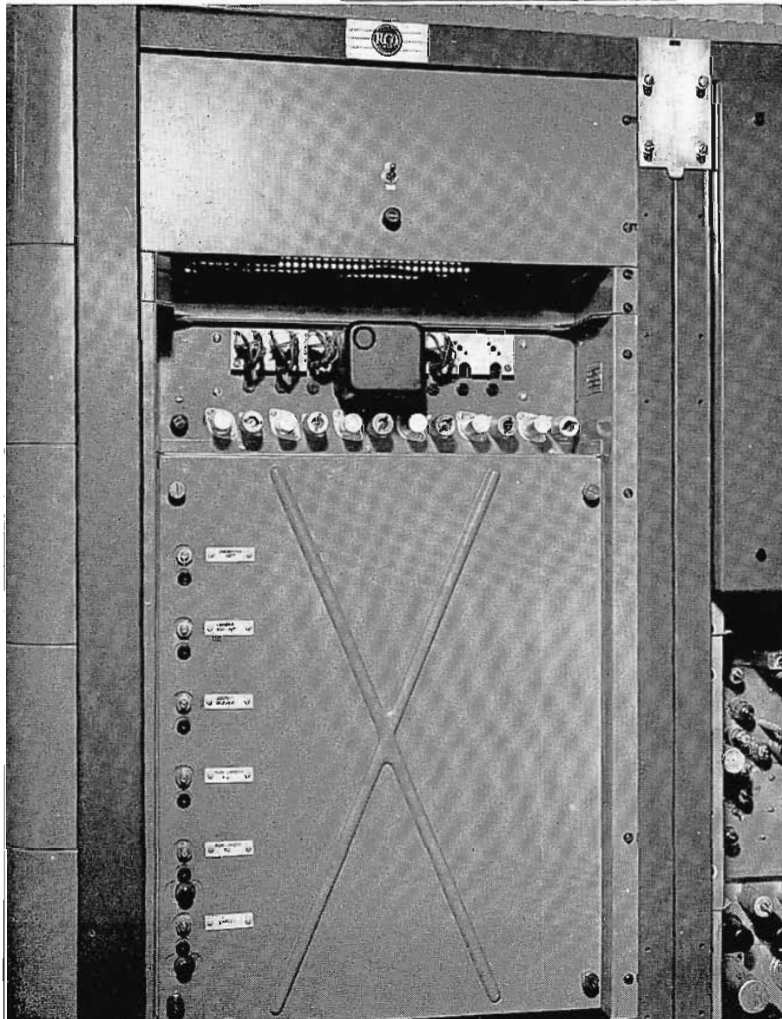

FIG. 4. Closeup of part of KGO-TV's video relay switching panel which is located in the master control room.

Berkeley on the opposite shore of San Francisco Bay. Offices now occupy the entire second floor, some with views commanding the city of San Francisco, others looking down on the broad expanses of the Pacific. The only room on the ground floor actually used for television production is the "great hall" which is now Studio B.

The large attic, used for storage and filing space, is topped by an octagonal glass-enclosed observation tower. Here, again, the love of beauty and commanding views held by the mansion's builder is utilized to full advantage by the KGO-TV engineers. Towering above the trees and surrounding hills, the tower now houses the microwave receiver used on many of the KGO-TV remote telecasts. From this point the engineers are able to receive direct microwave transmission from almost any points in San Francisco-Oakland area.

The larger facilities of Studio A are utilized by KGO-TV's big local shows. The Sunday afternoon variety show—"Malloy and Company"—requires considerable space for its many musical numbers and skits. Other shows shot in Studio A are "Sports Den"—a sport program featuring interviews with famous athletes in the area, and the fifteen minute bi-weekly afternoon participation show "Mail Bag of Tricks".



FIG. 5. View of KGO-TV's studio A. Walls and ceilings are covered with fiberglass bolts between steel studs, covered with glass cloth and chicken wire. The floor is linoleum over inch boards.

Control Room A serves both Studio A and Studio B—plus being the master control room for all video switchings. It is located at the end of Studio A—overlooking the studio through a double tinted 5 by 15-foot glass. The control room is arranged on two levels—the lower for video being 15 inches above the studio floor level, while the upper for audio and production is raised 37 inches. This excellent arrangement provides practically 100% visibility of the studio for all operators and producers and has been most satisfactory. Shading, video switching, projector control, and line switching take place at the lower video level where two engineers work while audio is controlled by one man on the upper deck.

Video Relay Switching

All camera switching is done by the technical director at the video control position associated with the "Air" monitor. This is actually an RCA TS-10A Video Switching Unit to which is fed the outputs from the three Studio Cameras, the two Film Cameras, and the relay receiver and network lines. The camera controls may be seen directly to the left of the technical director's position. Further control facilities are provided at his right. First is a preview monitor, next is a panel of remote controls and push-buttons. In this panel will be found controls for the 35 and 16mm projectors and the push-buttons for video switching of the transmitter line and the various preview and cue monitors

in the studio. To reduce the number of video cables required, this switching is relay operated in the form of a TS-20A Relay Switching unit located in the racks with the incoming line and distribution equipment. To the switching relay bank is fed the network and remote pickup lines, the studio line output from the TS-10A switcher, and direct lines from the two film cameras and one of the studio cameras. Outputs from the switching relays feed the transmitter line, the preview monitor at the technical director's position, and monitors in the announce booth, projection room, and the clients' room.

Relay receiver control, video patch panel, distribution and stabilizing amplifiers, video relay panel and miscellaneous

FIG. 6. KGO-TV SYSTEM
DIAGRAM OF VIDEO
FACILITIES.

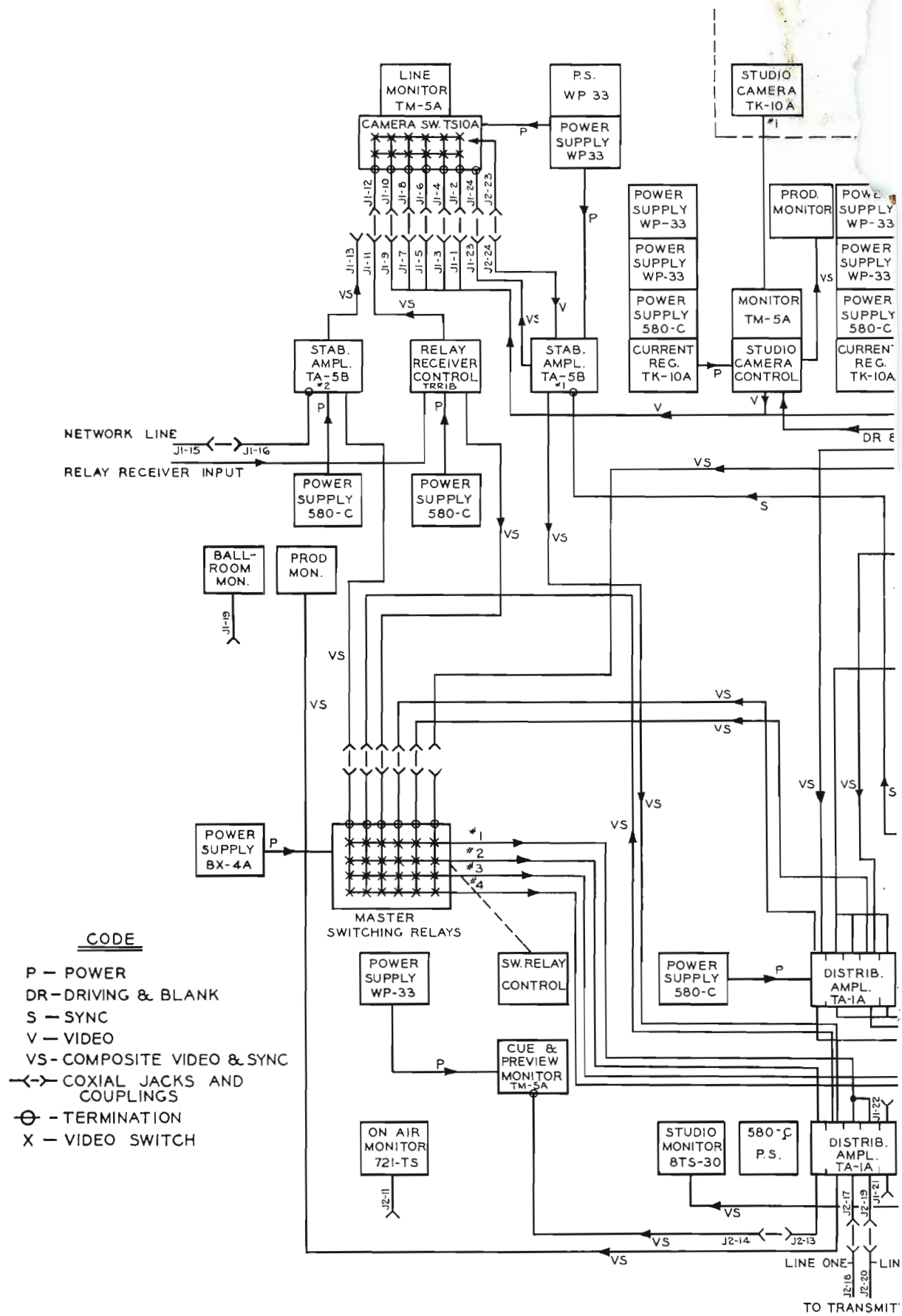

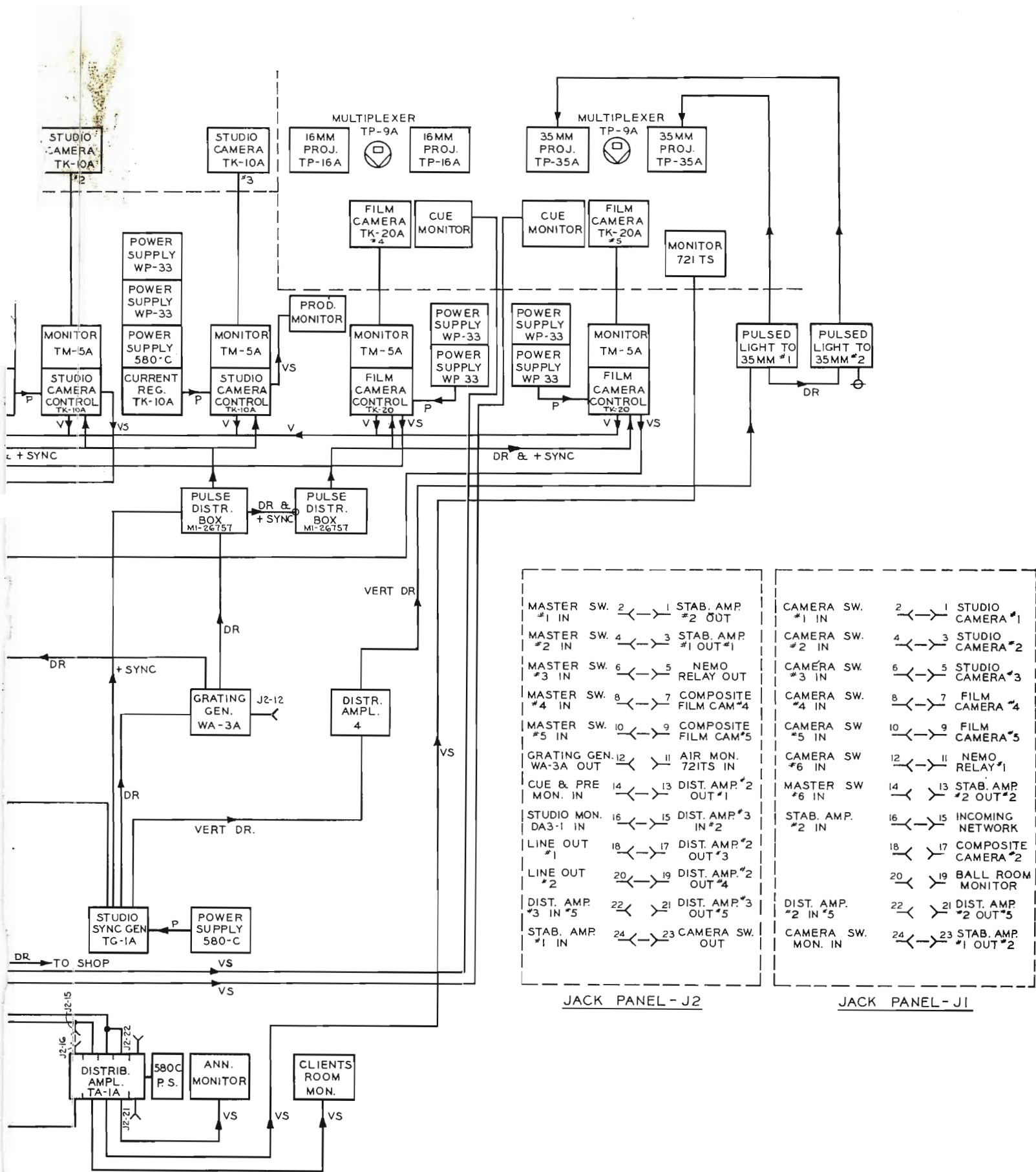

MASTER #1 IN	SW. 2	1	STAB. AMP #2 OUT
MASTER #2 IN	SW. 4	3	STAB. AMP #1 OUT #1
MASTER #3 IN	SW. 6	5	NEMO RELAY OUT
MASTER #4 IN	SW. 8	7	COMPOSITE FILM CAM #4
MASTER #5 IN	SW. 10	9	COMPOSITE FILM CAM #5
GRATING GEN. WA-3A OUT	12	11	AIR MON. 72ITS IN
CUE & PRE MON. IN	14	13	DIST. AMP. #2 OUT #1
STUDIO MON. DA3-1 IN	16	15	DIST. AMP. #3 IN #2
LINE OUT #1	18	17	DIST. AMP. #2 OUT #3
LINE OUT #2	20	19	DIST. AMP. #2 OUT #4
DIST. AMP. #3 IN #5	22	21	DIST. AMP. #3 OUT #5
STAB. AMP #1 IN	24	23	CAMERA SW. OUT

CAMERA SW. #1 IN	2	1	STUDIO CAMERA #1
CAMERA SW. #2 IN	4	3	STUDIO CAMERA #2
CAMERA SW. #3 IN	6	5	STUDIO CAMERA #3
CAMERA SW. #4 IN	8	7	FILM CAMERA #4
CAMERA SW. #5 IN	10	9	FILM CAMERA #5
CAMERA SW. #6 IN	12	11	NEMO RELAY #1
MASTER SW #6 IN	14	13	STAB. AMP. #2 OUT #2
STAB. AMP. #2 IN	16	15	INCOMING NETWORK
	18	17	COMPOSITE CAMERA #2
	20	19	BALL ROOM MONITOR
DIST. AMP. #2 IN #5	22	21	DIST. AMP. #2 OUT #5
CAMERA SW. MON. IN	24	23	STAB. AMP. #1 OUT #2

JACK PANEL - J2

JACK PANEL - J1

E TWO
TER



FIG. 7. KGO-TV has transformed this 15,000 square foot basement of the Sutro Mansion into a compact production unit which includes studio A, control Room A—as well as the transmitters, projection and dressing rooms.

video equipment—along with studio equipment—are located in four racks at the side of the control room. A 76-B5 console and two 70-D turntables are situated on the upper deck. This all adds up to a compact and efficient control room operation.

Studio "B"

As it is served by the same control room as Studio A, Studio B is actually KGO-TV's auxiliary studio. This "great hall" of the old Sutro mansion has had little change in its physical arrangement. With its beamed and vaulted ceiling two stories high, the 40 by 24-foot room provides space for a permanent kitchen set, living room set and several smaller sets. Modified for Klieg light outlets and camera and microphone cable, Studio B is equipped with two studio cameras and a Mole-Richardson boom—but still retains the huge stone fireplace and massive windows

on three sides that have made Sutro Mansion a San Francisco landmark.

This smaller studio is used for the afternoon Hostess' and Les Malloy week-day programs. As the former calls for a kitchen and living room set, Studio B offered the only possible site for these permanent installations. The latter Tuesday through Friday show features interviews with visiting celebrities with a desk as the set. Therefore, the small area required allows its production in KGO-TV's auxiliary studio.

Film Projection Facilities

Film projection facilities are located in the projection room—across the main corridor from the control room. Here are located two 16mm motion picture projectors, two 35mm slide projectors, two multiplexers, two 35mm motion picture projectors, a 3¼ by 4-inch lantern slide projector and

two film cameras. One film camera is mounted on a turntable to provide access to both 35mm motion picture projectors, to the 35mm slide projector and to the lantern slide projector which accommodates both opaque and translucent material. The test pattern is transmitted by means of a 35mm slide through a film chain.

More than adequate provision is made for storage of the day's run of film and for checking and splicing both 16mm and 35mm. All projector switching is done from a remote position in the control room, with the exception of the mechanical dissolve from one lantern slide to the next. Film camera control units are located in the control room.

Antenna and Tower

The tower at KGO-TV is a 428-foot triangular self supporting Ideco structure,

on top of which is a 4 element heavy-duty Pylon for KGO-FM and a 6 bay high-band Super Turnstile TV antenna. The base of the tower is approximately 40 feet from the transmitter, providing a reasonably short run for the $3\frac{3}{8}$ -inch transmission line. The feeder system is a standard diplexer to two transmission lines, with a phasing section in one line. The installation of the antenna involved no special problem. The four FM sections and the turnstile were placed in position in separate operations—after the turnstile was assembled and tested on the ground.

Field and Remote Equipment

KGO-TV's field equipment is housed in a standard RCA mobile unit built on a $1\frac{1}{2}$ ton chassis. The mobile unit is normally housed at the Twin Peaks studio-transmitter location. Its regular crew consists of seven engineering members, plus the required production personnel. Additional storage space in the form of cabinets have been added to accommodate the tools and spare parts necessary for extensive remote

operations. The normal complement of equipment consists of three camera chains, two pipe dollies, sync generator, switcher, microwave transmitter and two OP-6 and OP-7 audio units.

A portable 7-inch receiver is permanently installed as a cue monitor, and a yagi antenna cut to channel 7 is provided on a demountable pole at the side of the truck. A 24-foot collapsible aluminum ladder is part of the normal equipment carried aboard the unit.

Microwave reception of the remote video signals is accomplished from several pickup points about the building. An elevator is presently being installed to provide access to the 135-foot platform of the tower, upon which the receiver will be permanently mounted with provision for remote azimuth control in the control room.

KGO-TV's award-winning "Hoffman Hayride" is telecast in Studio A at Radio City—in the heart of downtown San Francisco. The "Hayride's" popularity necessi-

tates use of larger facilities than are available at Mount Sutro. Other remotes produced by KGO-TV are "Freddy Martin and the Admiral Band of Tomorrow" from the Mural Room of the St. Francis Hotel and the regular home football games at Stanford University, in Palo Alto, 30 miles south of San Francisco.

After a year and a half of operation, KGO-TV's Engineering Manager, "Shorty" Evans, says "selection of this site for KGO-TV's transmitter and studio operations has proved economical and efficient. In the event KGO-TV's need for studio space exceeds the amount now available and causes the studios to move elsewhere, the present location will always be an ideal transmitter site."

The general outward atmosphere of the Sutro mansion is still one of gracious living. But a glimpse of the steel towering above the turreted roof, and a step inside the bright metallic control room leaves no doubt that here is all the exciting and vigorous activity of a class A television station.



FIG. 8. View of the KGO-TV mobile unit which houses the necessary field and remote equipment. The regular crew consists of seven engineering members.

FIG. 1. Cut away view of the scanning unit. Light from Lamp "B" can only reach photocell "D" by reflection. Inside of housing is black so that reflective properties of tape "A" under aperture "C" govern intensity of light reflected to the photocell.

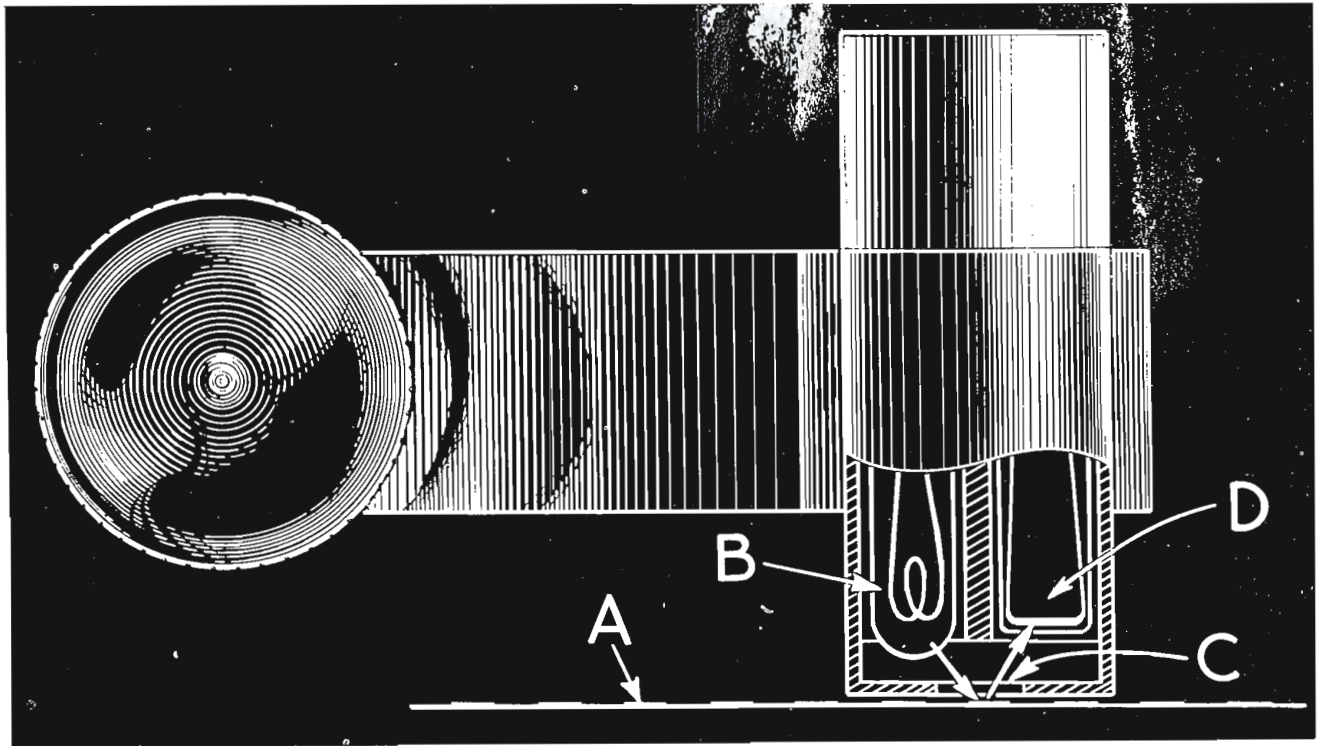

A SOLUTION TO THE MAGNETIC TAPE TIMING PROBLEM

By **D. R. ANDREWS**

Development Engineer, RCA Victor
Camden, N. J.

Introduction

The use of magnetic tape as a medium for recording radio programs is becoming more and more important. The many conveniences of tape recording is attracting the producers and artists, as well as the broadcasting technicians. The producers and artists are becoming more aware of the flexibility provided by its ease of editing and erasing. A complete show can now be recorded similar to the production of a Hollywood movie. Each selection may be recorded over and over until the director is entirely satisfied. The producer can then edit the recordings to produce precisely the type of show he desires. "Fluffs" may be easily removed and replaced. This provides a freedom of expression for the artist which is extremely convenient. During the editing process the show can be carefully timed so that the entire show will be completed without sacrificing valuable commercial time. The use of magnetic tape in this way is becoming so popular that some of the larger network stations are purchasing elaborate console type custom-built machines for editing facilities exclusively.

Broadcast stations are usually faced with a precision timing problem. Many of the major stations use automatic station breaks. This calls for very exact timing of the program and commercial material. In order to insure no loss of commercial time, the program material must be timed within one second in one-half hour. The dimensional stability of plastic base tape is not sufficient to guarantee that the recorded time will be maintained to such close tolerances during reproduction of the program. Both temperature and humidity conditions as well as tension, affect the physical dimensions of plastic materials. These dimensional changes may increase with time, especially if climatic conditions are altered. Therefore, programs which are shipped to other locations having different climatic conditions, or those stored for long periods of time may suffer severely in this respect. In such cases, the time required

for reproducing the program may vary considerably from the recording time. Tape manufacturers, as yet, do not specify any values of dimensional stability. Even if a value of one percent stability could be assured, it would still allow a total variation of eighteen seconds in a thirty minute program. Most broadcast stations would prefer to have this value reduced to less than one second, but heretofore have considered it useless to ask for such accurate timing.

Methods

It becomes very obvious that some means of timing control is not only desirable but very essential if magnetic tape is utilized to its fullest extent. Many different methods of accomplishing this have been suggested or tried.

A novel method¹ utilizes transverse magnetization to record a reference signal on the tape during the recording of the program. Transverse magnetization is accom-

¹ "Sprocketless Synchronous Magnetic Tape" by R. H. Ranger, *Journal of the Society of Motion Picture & Television Engineers*, March, 1950.

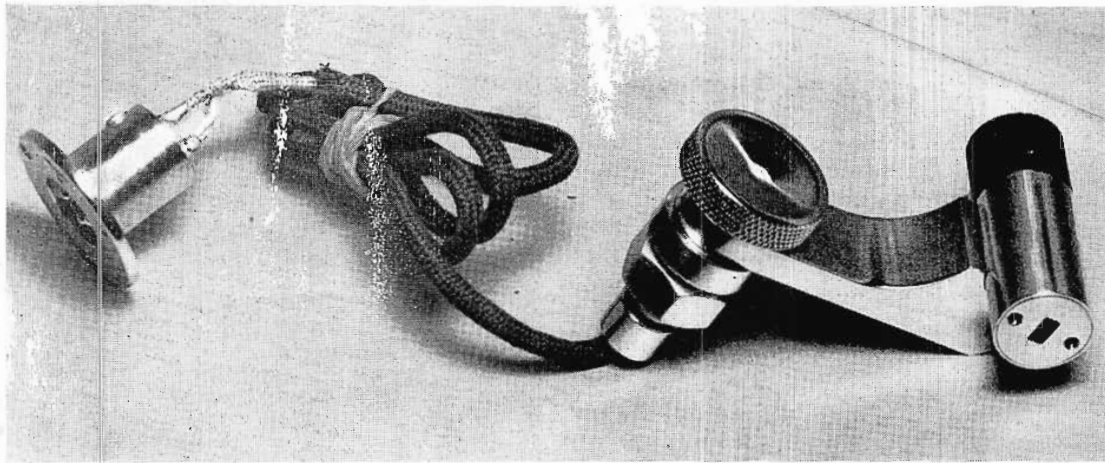

FIG. 2. Closeup view of the photocell scanning unit.

FIG. 3. Block diagram illustrating the operation of complete system.

plished by rotating the recording head 90 degrees so that the gap is placed parallel to the direction of tape travel. The signal recorded in this manner is reproduced during playback by a similarly oriented head and is used for synchronizing purposes.

A second system² makes use of a "high" frequency carrier (approximately 14 kc) that is modulated with a timing signal. During reproduction, the carrier is filtered from the program signal and after demodulation is used for synchronization. Of course, the operating frequency range of the program channel is somewhat reduced.

The system we have developed at RCA utilizes optical markings to furnish the timing signal. Since the signal markings are not magnetic, no unwanted signal will be generated in the reproducing head by the additional information stored on the recording medium.

The signal is produced by equally spaced bars printed on the reverse side of the tape. The printed bars are scanned with an optical transducer. The transducer is an extremely simple optical system. A grid is placed directly over the printed side of the tape. The grid is a mask with one or more holes to correspond with the markings on the tape. A light source is directed toward the grid. As the tape changes in color beneath the hole in the grid, more or less light is reflected back into a photocell and thus produces a signal which varies in frequency with the speed of the tape.

Fig. 1 shows a simplified cross-sectional sketch depicting the operation of such an

² "Picture-Synchronous Magnetic Tape Recording" by D. G. C. Hare & W. D. Fling, *Journal of the Society of Motion Picture & Television Engineers*, May, 1950.

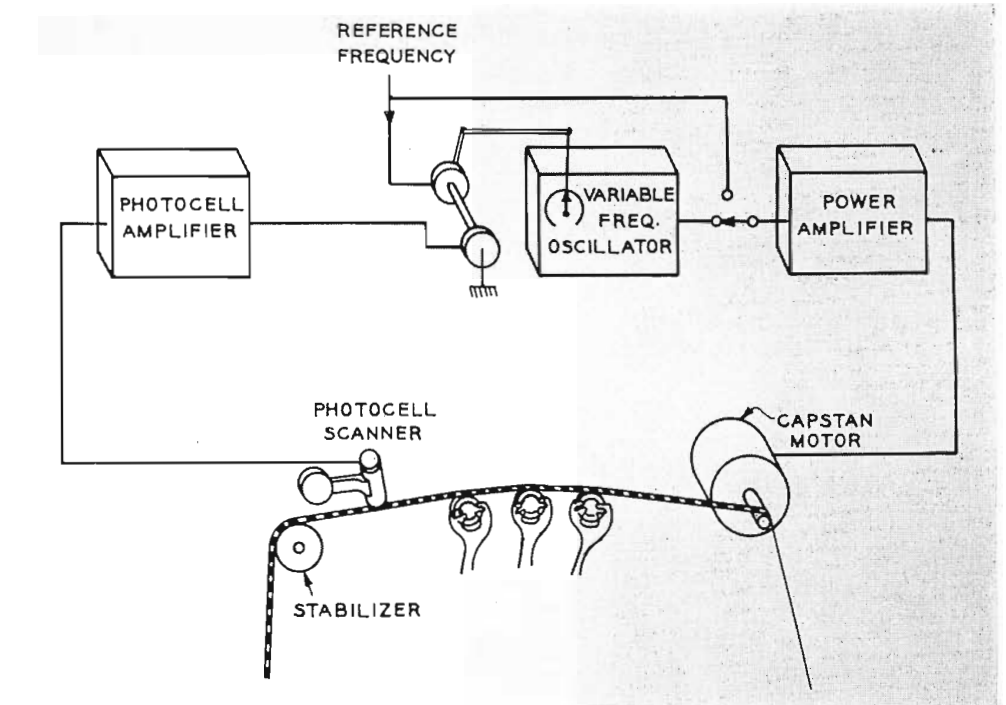

optical system. Part of the light from source "B" goes through the aperture or grid "C" onto the tape "A". The intensity of the light which is reflected back to the photocell "D" is partially governed by the color and gloss of the surface of the tape. The printed markings on the surface of the tape, therefore, produce a signal in the photocell whose frequency is directly proportional to the speed of the tape past the aperture.

The signal generated by the motion of the tape must be compared with some standard or reference frequency. The reference frequency may be obtained from a regular power supply or from a stable clock circuit type of power supply, if one is available. Some large broadcasting studios have such a circuit to insure the accuracy of clocks used for program timing. Since available clock motors are designed

to operate on 60 c.p.s. and the NAB standard tape speed is fifteen inches per second, the markings on the tape were placed four bars per inch. If it is desirable to operate the tape at the secondary standard of $7\frac{1}{2}$ inches per second, the markings of four bars per inch may still be used to produce a 60 c.p.s signal by means of a frequency doubling circuit.

Several methods of comparison between reference and photocell frequencies could have been used. One suggested method utilizes a simple beat note for driving the capstan motor. The signal from the photocell is mixed with a signal of twice the reference frequency. The beat note produced by this mixture will then vary in frequency inversely with the frequency of the photocell signal. The weakness of such a system lies in its inherent error. Corrections provided by such a system are only

partial. This type of system may be used to decrease the error but can never introduce sufficient compensation needed for complete correction.

A second method uses a two phase motor as an integrator. The signal from the reference frequency is used to furnish power for one winding of a two phase capstan motor. The signal furnished by the motion of the tape is amplified to excite the second winding of the motor. This creates an integrating device. If the phase of the current through the first winding leads that of the current in the second winding, the torque of the motor is increased, and inversely, if the phase of the current through the second winding leads that of the current in the first winding, the torque of the motor is decreased. Such a system is an instantaneous or phase integrating device and does not furnish a time integrating system as would be desirable for broadcast timing. The total memory or time storage which is possible is only a small fraction of one cycle. Therefore, if nothing occurs that causes the instantaneous time difference to exceed this very small value, the system may be very accurate. If this difference is exceeded, the time lost will never be recovered. Also, the instantaneous recovery rate will be so rapid that extraneous speed

fluctuations or "wow" may be introduced in the program material. Flutter or wow percentage does not depend directly on the amplitude of speed variation. By definition, flutter or wow is the percentage obtained by dividing the speed deviation by the mean speed times one hundred. Since the mean speed is a velocity term, the speed deviation must also be a velocity term and not amplitude. Therefore, very small, fast deviations may produce extremely high percentages of wow. This fact makes it imperative that any correction in speed must be accomplished at a very slow rate. In addition to the ill effects caused by the instantaneous speed changes, it may also be undesirable to drain sufficient power from the clock circuit of a broadcast studio to operate one phase of the capstan motor.

A third method providing a slow time integrating device may be designed by using two synchronous clock motors. One clock motor operates from the clock power supply. Such a motor never uses more than 4 watts from the power source. A second clock motor operates from the signal generated by the photocell with counter rotation to that of the first motor. The shafts of the two clock motors are coupled together with a flexible coupling. As long as the two frequencies governing the speed

of the two motors are identical, nothing happens, but any difference in the two frequencies causes the frame of one of the motors to have a tendency to rotate with respect to the frame of the second one. This might be described as a simple mechanical differential which needs no special gears or precision parts in its construction.

The rotation of the clock frame may be utilized in a number of different ways to obtain correction of the capstan speed. One obvious method is to mechanically shift a belt sideways on a tapered pulley. Such a method provides surprisingly accurate correction for timing purposes. However, due to imperfections in belts, speed fluctuations may be introduced by using tapered pulleys. It is practically impossible to find a flat belt which does not "wander" on the pulleys due to imperfections in the belt. This wandering on tapered pulleys obviously will cause speed changes. If guides are used to decrease the "wandering" the variation in friction caused by rubbing the guides will affect the speed. A second mechanical method may be arranged by driving a disc with a friction roller. Speed corrections may be introduced by shifting the roller radially with respect to the disc. The timing with such a system may be controlled very satisfactorily. Such a method is again handicapped with in-

FIG. 4. Circuit diagram of the photocell amplifier. Note that diagram is divided into stages as indicated by dashed lines marked with letters as follows: A—Preamplifier; B—Frequency Doubler; C—Clipper; D—Voltage and Power Amplifier; E—Relay Circuit; F—Variable Frequency Oscillator.

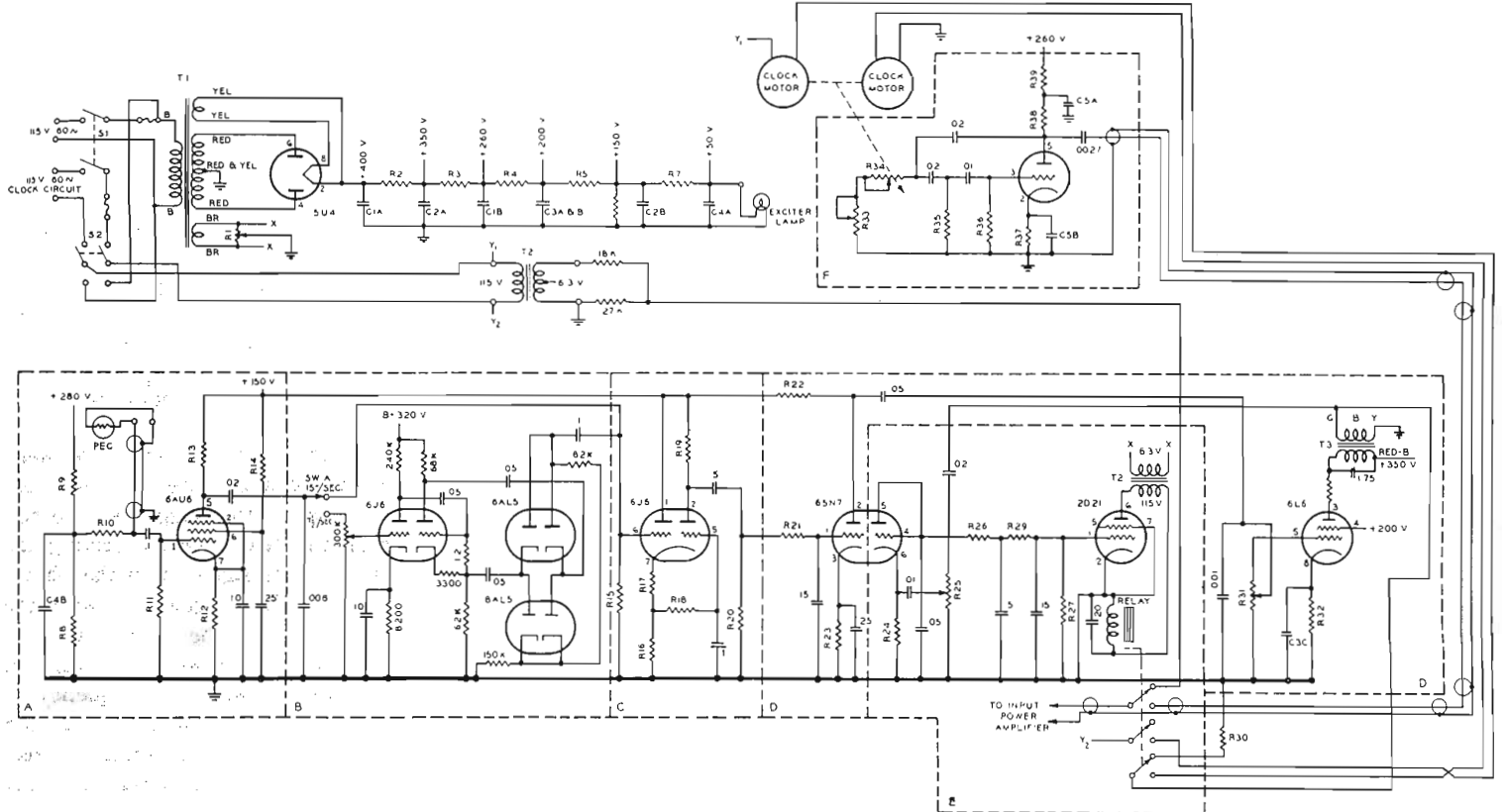
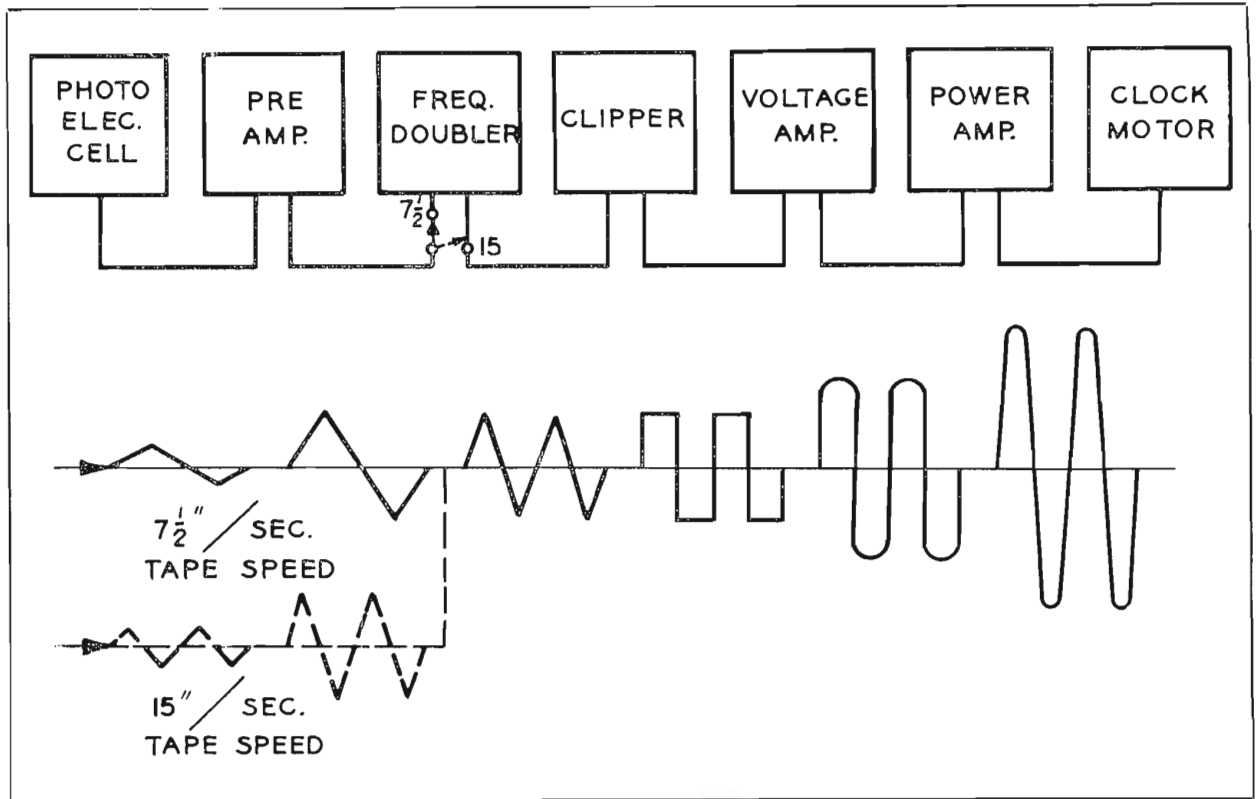

FIG. 5. Block diagram of the photocell amplifier showing waveform changes occurring in each section of the amplifier.



herent mechanical difficulties which introduce wow in the program material. The precision necessary in the construction of such a device to overcome these difficulties would probably make the cost prohibitive. Any type of mechanical system is also handicapped because the mechanical power developed by standard clock motors is extremely limited. Of course, special motors could be designed with sufficient power to operate a mechanical system if that were the only handicap to such a system.

The dual clock motor integrating system may be used very satisfactorily by providing an electronic correcting system. One obvious means of doing this is to have the speed of the capstan slightly more than required to drive the tape at the desired speed. The capstan may then be "slowed down" to the proper speed by means of an electronic brake. The power delivered to the electronic brake may be controlled by the rotation produced by the dual clock motor differential.

There is one serious difficulty encountered in using any type of "over-driven" system. If, for any reason, it is desirable to record or reproduce tape without synchronization, the machine will be operated at some speed which is higher than normal. This would make the system incompatible with standard unmarked tape.

The incompatible feature mentioned above may be eliminated by driving the

capstan with a synchronous motor as shown by the sketch in Fig. 3. The synchronous motor is driven with a power source of variable frequency when utilizing the synchronizing system, and with the regular fixed frequency power supply at other times.

The motion of the dual clock motor differential is used to vary the frequency of a local oscillator having a mean frequency of approximately 60 c.p.s. The signal from the local oscillator may be amplified with an inexpensive narrow band power amplifier to drive the capstan motor. A relay is also incorporated so that the input signal to the power amplifier is derived from the local oscillator when the optically marked tape is used. If standard unmarked tape is used, the signal which drives the capstan motor is derived from the clock circuit or reference frequency.

Circuits

The circuit diagram of the photocell amplifier is shown on Fig. 4.

The exciter lamp in the scanning unit must be heated with either direct current or alternating current having a frequency which will not interfere with the operation of the clock motor which is driven by the signal from the photocell.

Direct current for the exciter lamp might be obtained by simply inserting it in series with the amplifier power supply.

However, if such a method is used, it is extremely difficult to filter the power supply sufficiently to eliminate low frequency feedback effects or "motorboating". This difficulty was avoided by using a high voltage, low-current lamp and connecting it in the bleeder circuit of the d-c power supply. The particular lamp used was designed to be operated with 55V and .047 A. Many such lamps are now available requiring currents as low as .032 A.

The photocell might be one of the many types now available. However, a lead sulphide type was selected. One reason for this selection was because of its availability in very small physical dimensions. The glass bulb of the particular one chosen measures only $\frac{5}{8}$ of an inch long and $\frac{1}{4}$ of an inch in diameter. Cadmium sulphide cells are available in even smaller sizes (approximately $\frac{1}{4}$ -inch cube). The lead sulphide type was chosen also because of its sensitivity at the red end of the visible spectrum. Since all the better quality plastic base tapes are coated with ferric oxide (Fe_2O_3), their color is a reddish brown. The markings may be printed on this color with black ink and produce very good contrast if scanned with a red sensitive photocell. If black tape is used with white markings, the contrast is also sufficient with the same photocell.

The lead sulphide photocell is a variable resistance type. That is, the internal re-

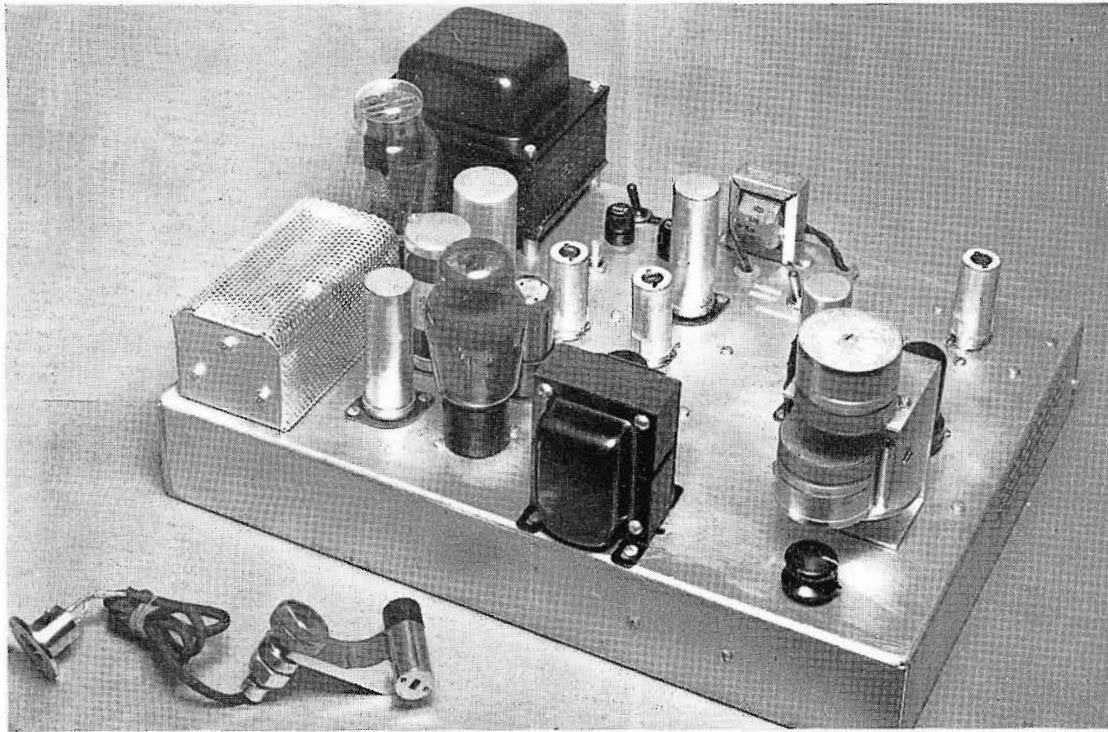

FIG. 6. Photograph of a complete synchronizing kit except for the capstan motor amplifier. Such a kit may be attached to an existing recorder.

**MORE AND MORE BROADCASTERS
ARE TAKING ADVANTAGE OF
THIS SPECIAL SERVICE**



The RCA Service Company maintains a complete factory repair shop for overhauling and repairing broadcast equipment. More and more AM, FM and TV broadcasters are taking advantage of this special service to make worn or damaged Microphones, High Fidelity Recorder Heads, Tape Recorder and Reproducer Heads and Test and Measuring Equipment perform like new again.

Broadcasters like having skilled, factory-trained experts work on their expensive equipment. They can be sure that all replacement parts are genuine factory originals. They like the way their equipment is repaired and returned in only a few days. And cost—even for major rebuildings—is low.

Lengthen the life of your equipment . . . increase efficiency . . . eliminate unnecessary replacement costs. Send your equipment in now. An estimate will be submitted, if you wish, before work is started. Address

**RETURN APPARATUS CONTROL
RCA SERVICE COMPANY, INC.
CAMDEN, NEW JERSEY**

istance varies inversely with the light applied to its sensitive area. The circuit requires a voltage supplied through a load resistance or inductance in the same manner as the anode of a vacuum tube.

The output from the photocell is amplified with a conventional preamplifier. If the tape is being operated at half speed or $7\frac{1}{2}$ inches/sec., the signal is diverted through a frequency doubling circuit, (Fig. 4, see Section B). This circuit consists of an amplifier, to regain the losses caused by the other stages; an isolation stage, to provide balanced input for the bridge; and a full wave bridge type rectifier, to provide the frequency doubling. The gain of the amplifier is so adjusted that the output signal has approximately the same level as that of the input but with twice the frequency.

The output from the frequency doubling circuit or preamplifier, as the case may be, is passed through a limiter or clipper circuit, (Fig. 4, see Section C). This circuit provides an output of constant amplitude even though the input signal may vary as much as five to one.

The output from the clipping circuit is then amplified sufficiently to operate one of the clock motors. Since the signal is changed to approximately a square wave in the clipping circuit, it is necessary to reshape the signal in the amplifier circuits. This is accomplished with resistance

capacitance filters as well as a capacitor tuning the inductance of the clock motor itself. This provides a signal at the clock motor terminals which is very near to sinusoidal.

Fig. 5 illustrates how the waveform of the signal is changed in the different sections of the photocell amplifier.

The relay which stops the clock motors and switches the signal for the capstan motor is electronically controlled. Normally the relay is energized. In series with the relay coil, is the cathode circuit of a thyatron tube. If the grid of the thyatron is biased negatively, the tube is cut off and the relay is de-energized. Bias for the thyatron tube is furnished by rectifying some of the signal generated by the photocell. The signal is furnished to the diode rectifier through a high pass filter network from the output of the power amplifier stage. This filter network may be adjusted so the relay will become de-energized as the frequency of the photocell signal approaches 60 c.p.s.

The variable frequency oscillator (Fig. 4, see Section F), furnishing the signal for the capstan motor uses an RC circuit of the phase shift type. Three RC phase shifting elements are used, with each unit shifting the phase approximately 60 degrees. One of the resistance elements is varied with the motion developed by the dual clock motor differential, and so drifts the frequency of the oscillator. It may be noted that the impedances of the RC circuits are

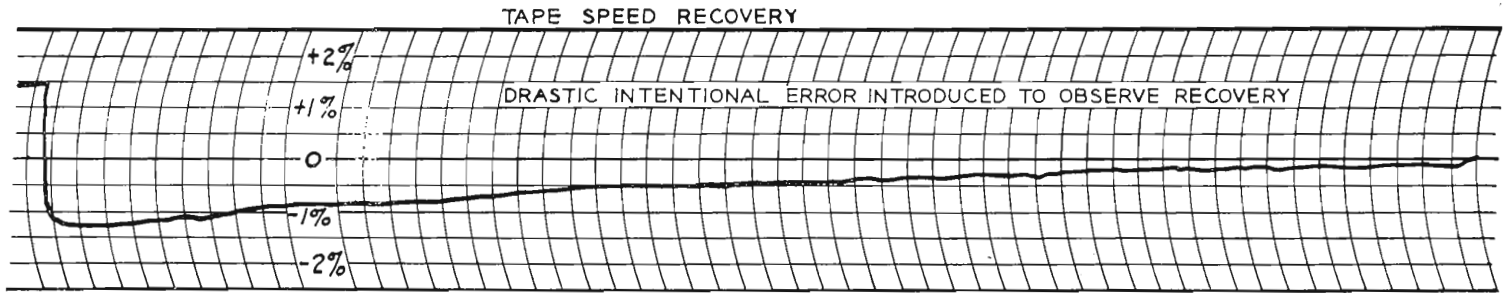

FIG. 7. Curve showing the speed of recovery after intentional error has been introduced.

kept as low as possible. This precaution was used to decrease the possibility of hum pickup in the grid circuit. Any oscillator has a tendency to "lock-in" on any signal appearing on the grid of the tube. If any "lock-in" occurs, the usefulness of the entire system will be jeopardized.

No circuit is shown for the power amplifier needed to drive the capstan motor. A conventional audio power amplifier may be used or a much simpler narrow band amplifier could be constructed.

Fig. 6 shows a photograph of a scanning unit and a chassis containing all equipment except the power amplifier, which may be attached to an existing tape recorder. Such kits have been installed and are operating very satisfactorily as field test units. In these test installations a conventional theatre amplifier was used to drive the capstan motor. The size of the scanning unit may be judged in this photograph. The scanning unit, exclusive of mounting arm, is a cylinder $\frac{3}{4}$ inch in diameter and 2 inches long.

Operational Tests

Repeated timing tests have been made with this synchronizing system. A synchronized tape was recorded with timing markers exactly 15 minutes apart. Reproduction of this tape was again timed. The timer was operated from the same source of power as that furnishing the reference frequency in both cases. The greatest differential between recording and reproducing time in several tests was three-tenths of one second. Of course, this error might be reduced still further at the expense of speed variation or "wow". The recovery rate was selected so that any speed changes would not be detected as "wow" but only as slow drift.

Fig. 7 shows a curve depicting the recovery rate of tape speed after an intentional error that had been introduced into the correcting device by manually rotating the clock motor differential. It may be noted from this curve that practically no oscillation whatever is apparent in the recovery curve.

Summary

A synchronizing system such as this is capable of furnishing very accurate program timing. Even though the plastic base

may shrink or stretch as much as $1\frac{1}{2}\%$ or 2%, a half hour program may be reproduced within less than one second of the recording time.

Speed changes are kept sufficiently slow, that no audible "wow" is noticeable.

Tape either with or without synchronizing markings may be used interchangeably. If unmarked tape is used, the machine will function the same as any standard recorder. Marked and unmarked tape may even be spliced together in one reel.



Field Engineering Service to Broadcasters...AM, FM, TV

RCA Service Company engineers are experienced in all the latest techniques and are equipped with the most modern specialized measuring equipment. The RCA Service Company has been working hand in hand with the nation's broadcasters for over 25 years.

OUR SERVICE TO BROADCASTERS...

- Installation supervision and measurements of transmitting, studio and accessory equipment . . . AM, FM or TV.
- Prompt help in emergencies. Technical advice, service, and assistance on special problems.
- Instruction and training of station operating personnel.
- Performance measurements and adjustments for station compliance with FCC regulations.
- Measurement and curves on FM and TV antennas and accessory equipment, including transmission lines, matching networks, diplexers.

(For service outside the U. S. A., consult your Authorized RCA Distributor)

NOW—restore the original quality of your RCA microphones, transcription pick-ups and test and measuring equipment under the new Factory-Reconditioning Plan. For complete details, write: Return Apparatus Control, Building 8-2, Camden, N. J.



RCA Service Company, Inc.

A Subsidiary of the Radio Corporation of America
CAMDEN, NEW JERSEY

PRECISION AM FREQUENCY MONITOR*

by R. S. McKINNEY

RCA Engineering Products Dept.

A new broadcast monitor known as the RCA Type BW-11A Frequency Monitor is commanding wide interest among broadcast engineers. The new monitor represents the culmination in the development of a precision instrument with a high degree of accuracy and dependability, as well as a minimum of attention required for maintenance.

An outstanding characteristic of this monitor is its sensitivity. Less than 10 millivolts of transmitter signal is needed at the high impedance input terminals (1/100 microwatt of power) so that a short wire antenna is all that is required in many installations to pick up an adequate signal. Alternately as much as 25 volts of transmitter signal may be applied without need for adjustments so that there is little likelihood of trouble due to strong stray fields occasionally encountered. In addition, the signal may actually be modulated in excess of 100% without causing more than a slight beat of the meter indication at certain modulation frequencies.

The complete monitor is contained in a single unit occupying $15\frac{3}{4}$ " vertical space in a standard 19" rack. The indicating meter has a 4" case and an illuminated scale which is uniformly divided in cycles from -30 to +30. The movement is a zero-center d-c microammeter covering 100-0-100 microamperes.

The front panel is free of controls because normally no operating adjustments are required. There are several indicators on the front panel. A single CHECK button provides a complete overall check on the performance of the monitor. Of the four indicating lamps, one red lamp indicates that the unit is connected to an energized power line and that power is being applied to the crystal oven circuits. An

adjacent white lamp indicates heater cycling. Another red lamp indicates that the monitor circuits are turned on. A toggle switch controls the power supplied to the monitor circuits. Those circuits are independent of the oven and may be turned off overnight if desired. A white lamp (and the meter lamps) are fully illuminated when a signal of adequate strength near the proper frequency is applied to the monitor. Even though the meter illumination is signal-controlled, it is free from flicker. Provision is made for an optional remote meter also with signal-controlled illumination.

The oven thermometer is illuminated and is mounted horizontally for easy reading. An open scale covering 68° - 72° C permits direct reading to 0.1° . Sustained changes in line voltage over the range of 105 to 130 volts, and ambient temperature changes over a range of 25° to 55° C will

not cause changes totalling over 0.1° . For ambient temperatures not more than 55° C, the variation of temperature over a heat cycle will not exceed 0.01° .

Operation of the BW-11A can be seen by reference to the block diagram, Fig. 3. The transmitter signal, after passing through an untuned wide-band amplifier, is combined with a reference signal in a pentagrid converter. The reference signal is obtained from an accurate temperature-stabilized crystal oscillator 1000 cycles below the assigned transmitter frequency. The converter output is then passed through a limiter and a 1000-cycle tuned amplifier to remove irregularities caused by program modulation. The resulting constant-amplitude sine wave is then amplified and fed to a diode balanced discriminator, which produces a direct current proportional to the frequency deviation. This current is fed to the meter on the



FIG. 1. Front panel view of the BW-11A Frequency Monitor. The front panels can be raised and lowered for access to the circuits. The horizontal opening is to the oven thermometer which is illuminated during operation.

*FCC Approval Number 1471.

front panel which indicates frequency deviation directly in cycles per second.

Signal lamp and field strength indicator serve to indicate that a signal is being applied to the monitor and that circuits preceding the initial audio stages are in operation. Depressing the CHECK button decreases the discriminator center frequency approximately 5 cycles, causing the deviation indication to shift +5 cycles when the circuits up to the meter are operating correctly.

For ease of frequency correction after periodic checks, and for ease of maintenance, all circuits are accessible from the front of the rack. The stainless steel knob at the center of the panel is a captive screw which, when loosened, permits dropping the lower half and raising the upper half of the hinged front panel. Dropping the lower panel exposes an oven access hole for crystal frequency adjustment. Provided nearby in a handy mounting dip is a screwdriver for this adjustment. Also behind this panel is a phono jack from which a sine wave heterodyne signal is

(Continued on next page)

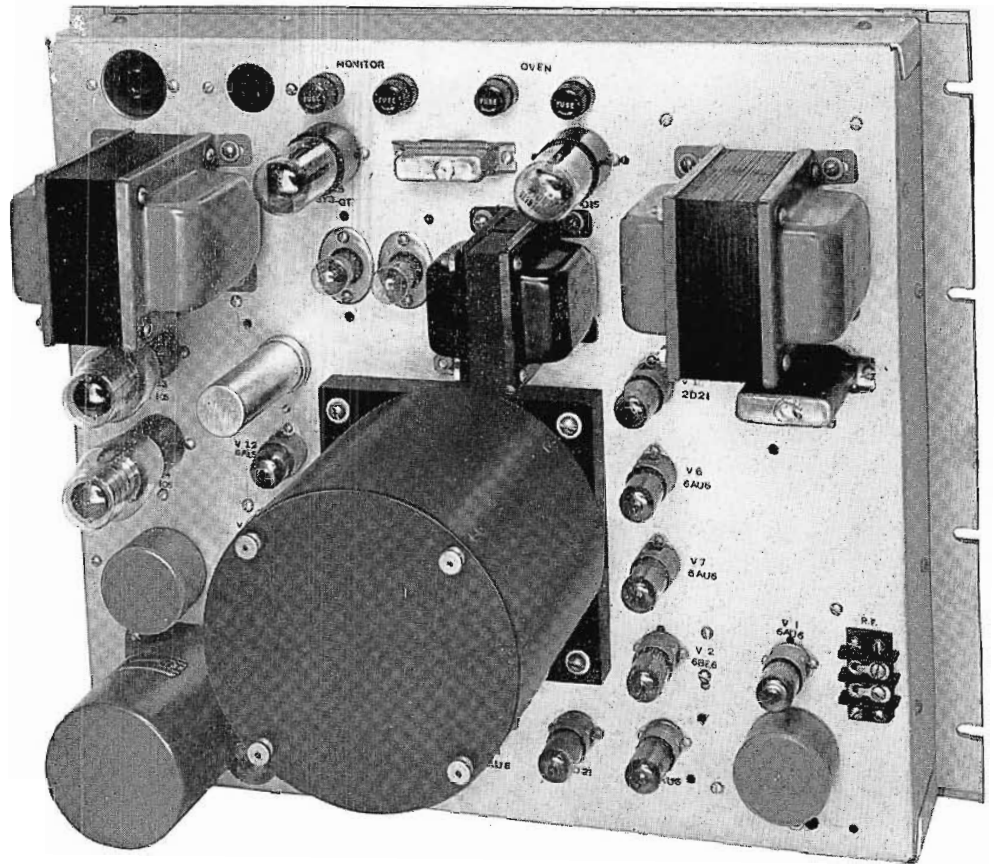
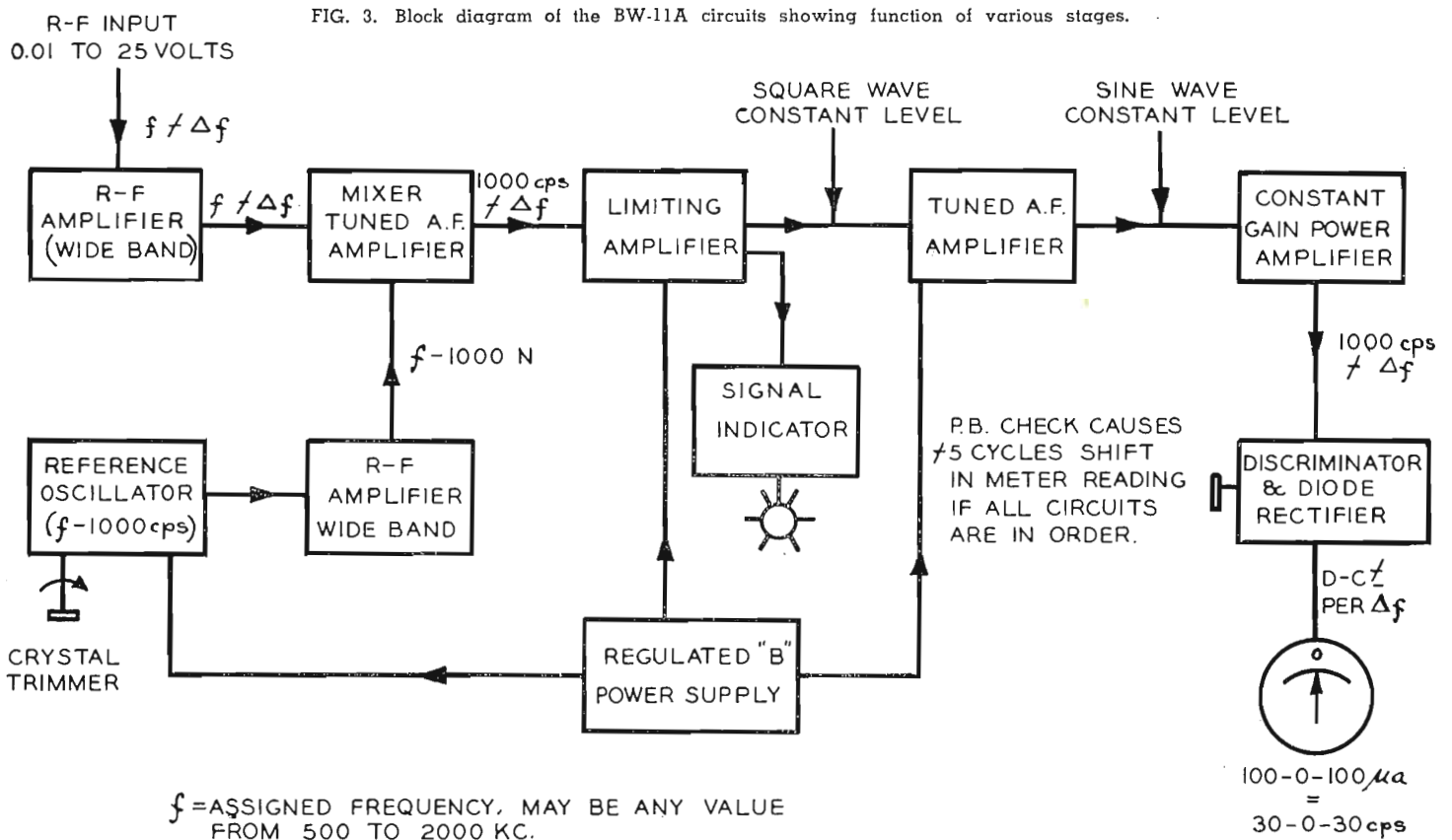

FIG. 2. Rear view of the BW-11A Frequency Monitor. The crystal oven is the cylindrical component in the center.



f = ASSIGNED FREQUENCY, MAY BE ANY VALUE FROM 500 TO 2000 KC.
 Δf = DEVIATION FROM ASSIGNED FREQUENCY RANGE OF INDICATION IS PLUS/MINUS 30 cps.



-----TYPE TM-2B

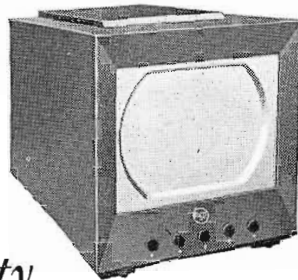

Low-cost, high-quality

TV Picture Monitor —with a dozen uses

Here is a professional 12½-inch picture monitor you can set up any place in your station—control rooms—announcers' booths—clients' viewing rooms—offices. It is completely self-contained with power supply. It is readily adaptable for portable service. Picture quality meets the requirements of the most critical director.

In the TM-2B, 6-Mc bandwidth permits use of closed-circuit signals—such as the signal from a control room. High-impedance video input makes it possible to terminate the signal in the monitor—or to “loop”

the signal through several monitors. Vertical scanning can be switched for “mirror viewing.” Removable controls make it easy to operate the unit “remote-control” (from a program console, for example).

A special version of the TM-2B . . . using a 10-inch picture tube . . . is available for rack-mounting, or as a monitor in a program console.

One of the handiest video units a station can own. Order yours from your RCA TV Equipment Representative. Or from Dept. 19LA, RCA Engineering Products, Camden, N. J.



available, and a meter switch which permits switching the deviation meter to different circuits of the monitor to check signal and plate supply voltages. Also exposed is a test switch and a screwdriver control for diode zero adjustment. Most of the monitor circuits are exposed for continuity checks when the lower panel is dropped.

Raising the upper panel exposes the 1000-cycle zero control, the meter sensitivity control, and the signal lamp control. These controls are not normally to be adjusted by the user. Shroud bushings are provided around these screwdriver controls to prevent their being accidentally thrown out of adjustment. An adjustment screw for setting discriminator frequency is provided for initial calibration of discriminator circuits, and is not to be used to compensate for crystal oscillator drift. To do so would affect the performance of the monitor.

As an overall picture of stability in the BW-11A, variations in line voltage over a range of 105 to 130 volts, and ambient temperature changes from 25° to 55° C, together with changes in tube characteristics will not cause variations in deviation indication totalling over plus/minus 4 cycles for a transmitter frequency of 1600 kc.

Crystal units for the BW-11A Monitor are supplied unaged, and the monitor is not adjusted to frequency before shipment. Installation consists of mounting the monitor (weight approximately 60 lbs.) in the rack, installing the plug-in crystal unit in the oven, applying oven power for a minimum of six hours, and then adjusting the crystal oscillator trimmer for proper deviation indication with a known transmitter frequency applied. Further corrections may be applied on the basis of frequency checks as the crystal circuit ages. The oscillator frequency may shift several parts per million in the first few months of operation, but thereafter aging should become negligible because of the low level at which the crystal is operated and because of the extreme constancy of temperature at which critical oscillator circuit components are maintained.

Crystals for different frequencies may be supplied without reference to the oscillator circuit by calibration to plus/minus 0.002% accuracy at operating temperature of 70° C with a TS-330/TSM Crystal Impedance Meter or equivalent, on the basis of series resonance with 32 mmf capacity added in series with the crystal unit. The oscillator trimmer has a frequency adjustment range which averages about 0.01%.



HAM FORUM

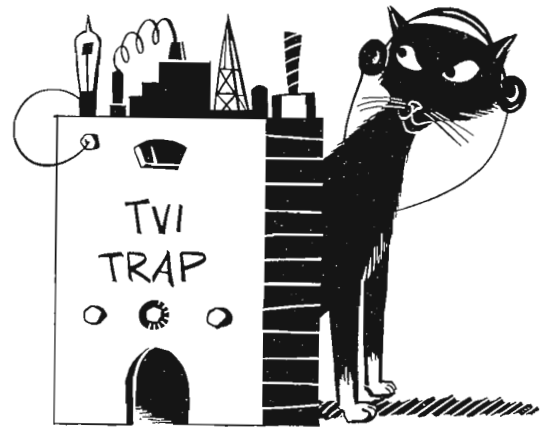

Hi fellas—

Many thanks for your best wishes for the success of the Ham Forum. We've received letters, postcards, QSL's . . . and even phone calls . . . W3ZS, John Stenger of WBAX, Wilkes Barre, Pennsylvania, called to say he will have something for us later. John's not on the air . . . taking it easy under doctor's orders. . . . From Brookline, Pennsylvania, W3KDE, Harold H. Liggitt sends his QSL. Harold is active with the Havertown Emergency Radio Net on 146.8 mc . . . works 14 mc, and is a member of the Engineering Staff of WDEL, Wilmington, together with W3BXI, W3HXK and W3MOP.

DONALD-DUCK HEARD FROM

An interesting letter came in from W7HPE, Chief Engineer of KODI, Cody, Wyoming. I'd like you to read it in part:

"I saw the Good News about the Ham Forum, so thought I would drop you a line or two while it is fresh in my mind! Sure think it is a FB idea, and will be looking forward to the next issue of BROADCAST NEWS.

"I really don't have very much dope to pass along, but here's what there is:

"So far as I know I am the only member of the 'Donald Duck' club in the fair state of Wyoming! Yes, I operate Single Sideband Suppressed Carrier and can be found on the high end of 75 or most any place on 20. The rig here starts out with a modified W1JEO/6 crystal filter exciter unit and ends up with a pair of 828's (yes they are taken out of our BTA-250L . . . they still work fine for RF when they will no longer balance up for modulators!) running Class AB1 with about 250 watts peak input. The receiver is a modified BC 312 which works vy FB. Antennas are an end fed half-wave for 75 and a single section '8JK' for 20.

"75 is getting pretty noisy now so most of my operating will be on 20 this summer. Can always use some more contacts on 20 as it seems a lot of the boys there don't know what SSB is and don't bother to try to tune the stuff; so I burn up a lot of juice calling CQ!

"I am the only Ham in Cody, however there are several prospects for the Novice Band as soon as that is available. At pres-



WØCIK Transmitter Room. Present transmitter runs 150 watts to pair of 24-G's.

ent I am trying to help some of the boys along with their theory so they will be ready to take their exams the first of July.

"I will certainly recommend SSB to any Ham who is getting just a little tired of the "cut and dried" stuff. I've got more fun out of it in the last few months than I have out of Ham Radio for several years. No foolin', it is a lot of fun to play with!

"As I said before I will sure be looking forward to the next issue of BROADCAST NEWS, not only because of the Ham Forum but also for all the fine dope it has in it. 73 to you and all the gang at Camden.

Phillip H. Barnhart W7HPE"

Thanks, Phil—we will be on the lookout for your DD.

Address correspondence to:

HAM FORUM
Marvin L. Gaskill (W2BCV)
Associate Editor, Broadcast News
RCA, Camden, New Jersey

Many of you will recognize the smiling face you see in this photo as that of EX W8MTP John Dearing, RCA Service Co. John is standing on the batwing of a TV antenna atop Empire State Building, 1400 feet above New York City . . . RCA Service everywhere!

FULL GALLON AT WØCIK

WØCIK, Gene Courtney of KAKE, Wichita, Kansas, has nearly completed a new 1-kw transmitter using a 4-400A in the final modulated by 4-125A's Class AB₂. . . . New rig features TVI proofing, band-switching 160 through 10 meters, speech clipping and filtering, and 110- or 220-volt operation with "hi-lo" power switch. Complete rig, excluding the exciter, is built in a 35" rack . . . WØCIK has pictures of it, too. Send them along, Gene, with some circuit details.

Let's hear from you, Broadcast Hams.
73 . . . W2BCV



TELEVISION TRANSMITTER MONITORING

by
R. A. BOOT & I. E. GOLDSTEIN
 Engineering Products Dept.

In making the choice of a monitor to observe the picture being transmitted, it is important to consider the purpose of the monitoring operation—whether to present a good-looking picture for the entertainment of the operator, or to present a picture which has sufficient fidelity to show the small inherent system defects that will appear on a high-quality home receiver. Visual monitoring is therefore fundamentally different from aural monitoring where the audio transmission can be made almost perfect and defects occur only in the receiver.

The system of television transmission with the partially eliminated lower sideband as used in this country provides wholly acceptable picture quality and results in efficient use of the available television frequency spectrum, permitting the greatest number of channels. Should the 4 mc of video information required for acceptable picture fidelity be transmitted employing double-sideband techniques, a bandwidth of approximately 9 mc, including sound, would be necessary. The alternative to double-sideband operation, therefore, is the inclusion of primarily a single sideband within the 6 mc channel, thus facilitating transmission of the desired 4 mc of picture information. This basically is the vestigial sideband system diagrammed in Figs. 3(a) and 4(a).

Inherent Distortion

However, varying degrees of picture distortion, barely discernible during normal program telecasting, become evident to the critical eye when a test pattern with adequate resolving power is used. Picture distortion resulting from sharp high-frequency video cutoff and an undesirable phase response due to the transmission of a vestige of the lower sideband are often observed as leading whites, trailing smears, ringing, and lack of picture detail. It should be emphasized that this distortion, in particular leading whites and trailing smears, exist because of the stipulated lower sideband suppression. If the transmitted lower sideband is attenuated the required amount, this distortion will be evident regardless of where in the visual

----- DISTORTIONS INHERENT IN

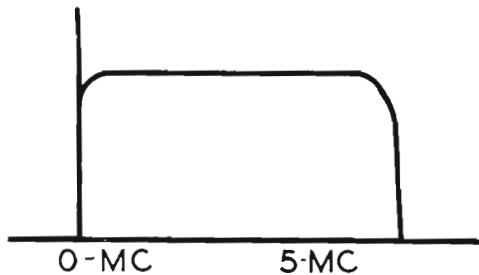

FIG. 1(c). TT-5A Modulator Monitor kinescope presentation. The approximately 7 mc of video information for the modulator location results in top picture quality with negligible distortion.

FIG. 1(b). ▼

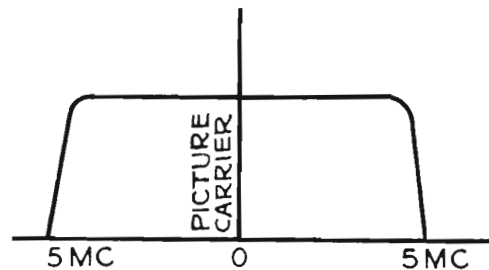
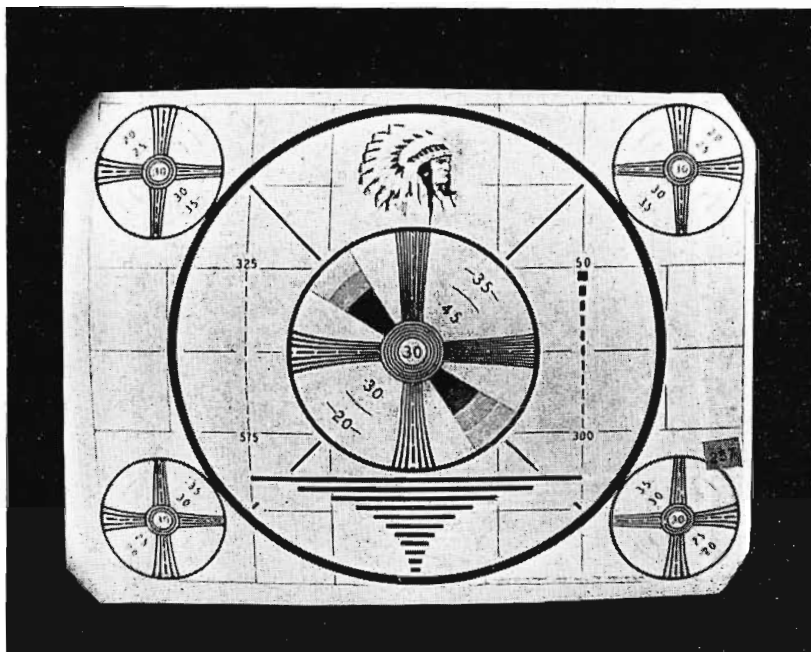
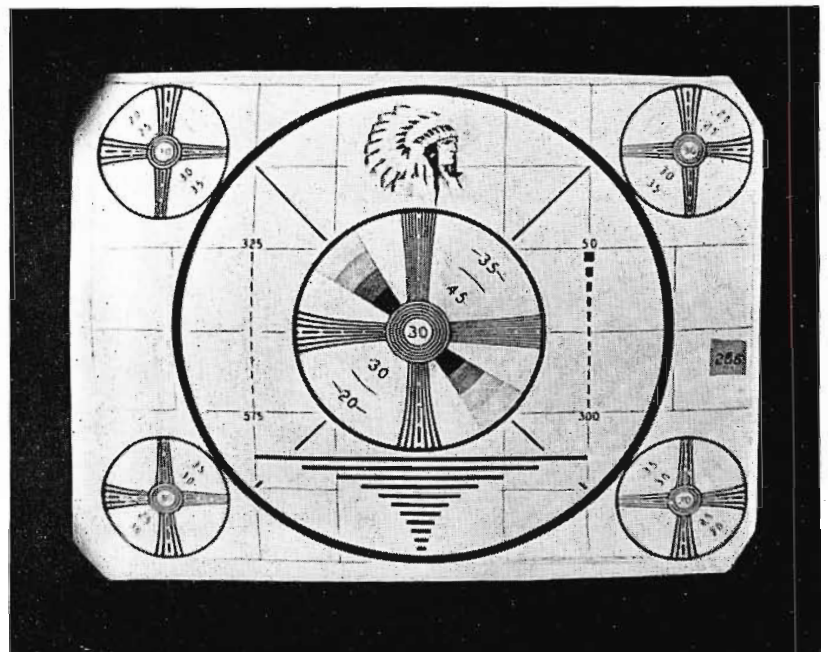

FIG. 2(a). Diode detection of essentially double sideband transmitter output, indicating smearing at approximately 400 lines (over 5 mc) on vertical wedge—a result of 5 mc video cutoff characteristic of this location. FIG. 2(b). ▼



transmitter system the lower sideband is suppressed.

The purpose of this article is: (1) to point out the fundamental departures of frequency and phase response to be expected in the vestigial television system, (2) identify departures with certain types of picture distortion, and (3) to associate these deteriorations in picture quality with various conditions of visual monitoring to permit the observer to distinguish between picture distortion inherent in the vestigial sideband system, and that caused by faulty or improperly adjusted transmitting and monitoring equipment.

The off-the-air monitor used for such tests should be equivalent to a high quality commercial receiver, presenting as nearly as possible an indication of the picture as potentially seen on the home receiver. Conceivable phase correcting networks should

be avoided in the visual monitor since they at best result in questionable signal improvement while at the same time altering the signal as compared to that eventually detected in the home set. In addition, the monitor should be designed to permit monitoring of all output circuit locations from the transmitter proper where the signal is essentially double sideband, to the antenna feed where most of the lower sideband is suppressed and full sound power is present.

Distortion inherent in the primarily single sideband system can be readily related to the amplitude and phase departures previously mentioned. A sharp white to black transition is equivalent to modulating the transmitter with a square wave and observing the wave shape in the vicinity of the leading edge of the square wave response. Thus, leading whites, trailing smears, ringing, and lack of detail have definitely related square wave characteristics.

Leading Whites and Trailing Smears

Specifically, leading whites and trailing smears may be directly attributed to vestigial sideband transmission. The radiated vestigial sideband TV signal is such that approximately 0.75 mcs of the lower sideband is transmitted with little attenuation. Upon detection, corresponding lower and upper sideband components are complementary and a demodulator input characteristic similar to that shown by the linearly sloping dotted lines in Figs. 3(a) and 4(a) is required to obtain uniform video amplitude response. This is the RTMA recommended receiver response curve for vestigial sideband reception.

Conventional amplitude modulated systems of course give rise to a symmetrical set of sidebands. Characteristics of these circuits are such that the sidebands are in phase opposition. Thus, upon detection, the net phase shift is usually zero or a small value. With the use of an unbal-

TELEVISION TRANSMISSION

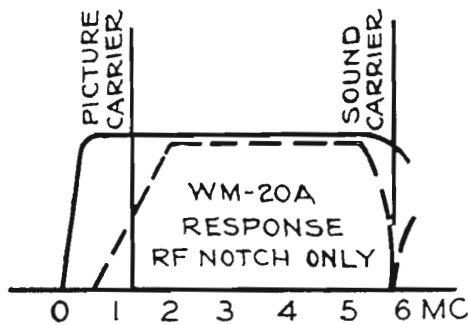

FIG. 3(a). WM-20A Demodulator Monitor presentation of required partially suppressed lower sideband transmission characteristic, as sampled between sideband filter and diplexer. Distortion including leading whites and trailing smears inherent to suppression of the lower sideband is in evidence. A slight amount of ringing evident at 350 lines, resulting from necessary 20 db r-f sound carrier trap in demodulator.

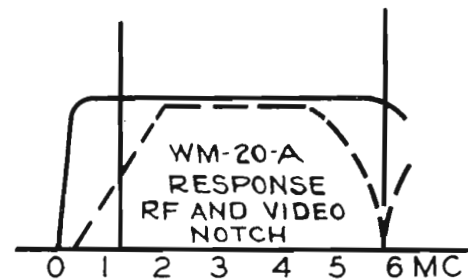
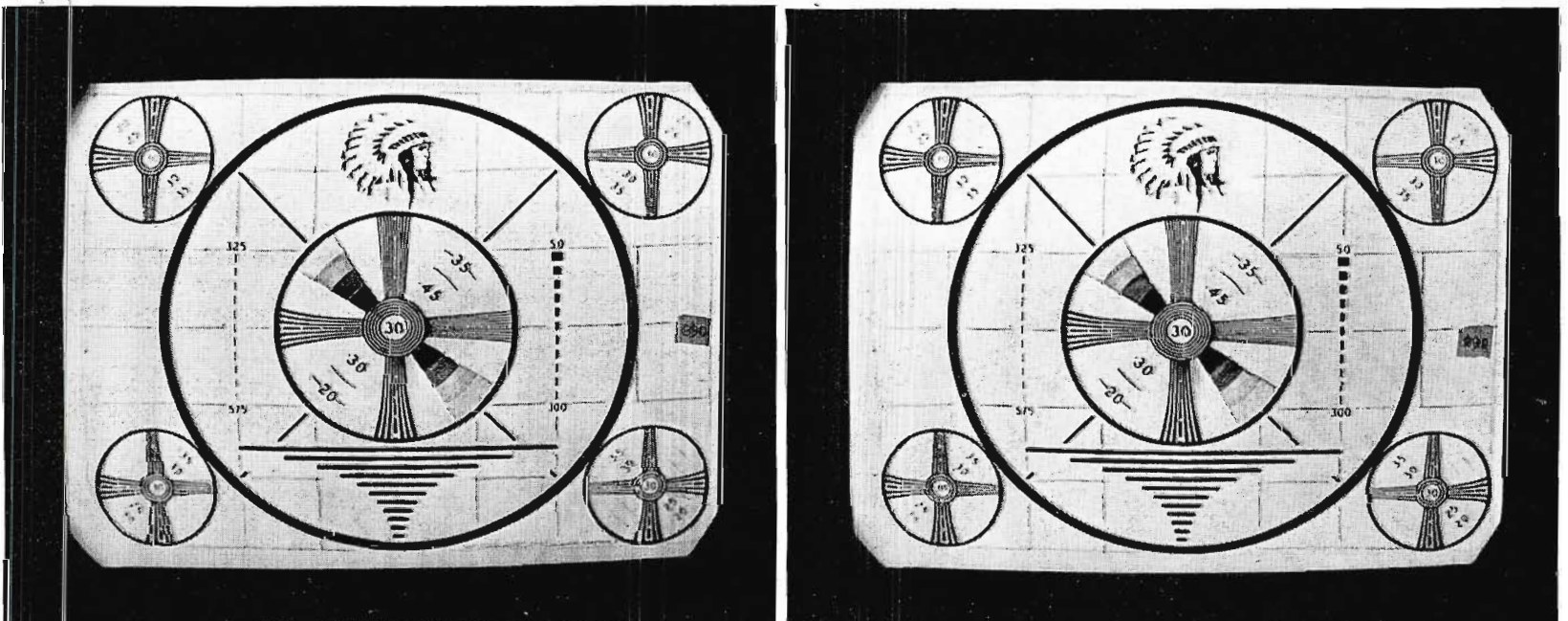

FIG. 4(a). Essentially off-the-air presentation as sampled beyond the diplexer where full sound power is present, along with required vestigial transmission characteristic. Increase in ringing evident, resulting from slightly reduced video cutoff as established by necessary sound notches. Demodulator equipment under these conditions equivalent to or better than high equality receiver.

FIG. 4(b).



anced set of sidebands or if the carrier is not located in the geometrical center of the band, this canceling no longer occurs. The vestigial sideband system is of the latter type, and hence phase distortion is encountered. This phase distortion at low video frequencies alters the square wave response in the receiver such that a dip precedes the transition with a gradual slope to the top of the wave following the transition as shown in Fig. 5. This "dip" is observed as a leading white (whiter than white) immediately prior to a white-to-black picture change where the line of separation is vertical. The gradual slope is the commonly observed trailing smear also evident for sharply defined bordering half tones.

Ringling and Lack of Detail

Whereas, these leading whites and trailing smears are introduced because of the suppression of the lower sideband, ringing and a certain loss in detail will be found in any practical television system, depending only on the high frequency video cutoff characteristic and associated high frequency relative time delay. Ringing, probably the most pronounced and annoying of the types of distortion, is evident in the square wave response as a ripple along the top of the square wave. In the picture, this appears as a multiple repeat adjacent to well-defined bordering picture elements. Fourier Analysis indicates that a perfectly flat top on the square wave would require an infinite frequency response. The rapid high frequency video cutoff introduced by the receiver circuits required to suppress the sound carrier results in the curtailment of certain high frequency components, and has associated with it a relative time delay error, both of which influence the degree of ringing.

Picture detail is essentially determined by the rapidity of transitions on the kinescope for well-defined bordering half-tone picture elements. The square wave characteristic related to picture detail is the labeled rise time or slope for the edge of the wave as shown in Fig. 5. Once again, Fourier Analysis indicates this slope to be a function of the high frequency components, the higher the cutoff frequency for the given system the steeper the slope of the square wave response and the finer the resulting picture detail.

A series of off-the-kinescope photographs of test patterns is presented in Figs. 1 to 4 inclusive. These patterns depict degrees of distortion present at various points in the transmission system. The monitor used in obtaining these photographs was an RCA WM-20A Vestigial Sideband Demodulator. This unit is an extremely adaptable visual

demodulator, characterized by constant input impedance, and a response which approaches the RTMA recommended receiver response curve.

Fig. 2(b) was obtained by detection of the transmitter output using a diode. As indicated by the accompanying diagram, Fig. 2(a), both sidebands are present. The bandwidth at this location is relatively quite broad (approximately 5 mcs per sideband) and the test pattern is very sharp showing negligible distortion. A detailed comparison with Fig. 1(b), which is the modulator monitor pattern for the TT-5A transmitter, shows cutoff to occur between 400 and 450 lines for the transmitter output. The modulator signal shows perfect resolution to 500 lines. This is to be expected since the bandwidth at the modulator is wider than the approximately 5 mc sideband transmitter output.

Use of the diode detector following the vestigial sideband filter is not possible because of the unbalanced sideband characteristic at this point. In the TV demodulator as in any standard receiver, an input response approaching that recommended by the RTMA must be incorporated to realize uniform video output. In addition, it is desirable to have at least 40 db sound carrier isolation. This isolaton is specified to minimize the 4.5 mc beat between sound and picture carriers, and to suppress the detected sound carrier component which could introduce error in measuring depth of modulation. The pattern of Fig. 3(b) corresponds to these conditions of monitoring, where the 20 db r-f notch was inserted in the WM-20A equipment to supplement the 20-30 db sound isolation due to the diplexer. A slight amount of ringing is noticeable centering around 350

lines. This ringing is the result of the 4.5 mc cutoff characteristic of the r-f filter. Leading whites and trailing smears, although of minor significance, are present also.

Monitoring on the antenna feed line requires both the r-f and video filters in the demodulator to maintain sufficient sound isolation. Under these conditions, the overall response is still equivalent to or better than that of a high quality receiver, but the slightly reduced cutoff frequency due to the video notch introduces an increase in distortion as shown in Fig. 4(b). Ringing is slightly more pronounced and becomes evident sooner, between 250 and 300 lines. When monitoring at this location and under these conditions, the rectified d-c component of the sound carrier may introduce several percent error in depth of modulation measurements. Therefore, a correction factor should be employed to insure proper reading.

The salient limitations of TV monitoring have been presented. Thus, it can be expected that the TV system as used in this country will contain a small amount of picture distortion. With this in mind, the proper evaluation of master monitor indications will be of considerable worth in maintaining high quality picture transmission. The visual monitor should therefore be capable of reproducing the transmitted picture with sufficient accuracy so that the inherent distortion of the partially-suppressed lower sideband system can be correctly evaluated. In this way any corrective measures for this distortion (such as those which have been considered by the RTMA for insertion in the transmitter input) can be appraised for their effect on the picture shown by a high-quality home receiver.

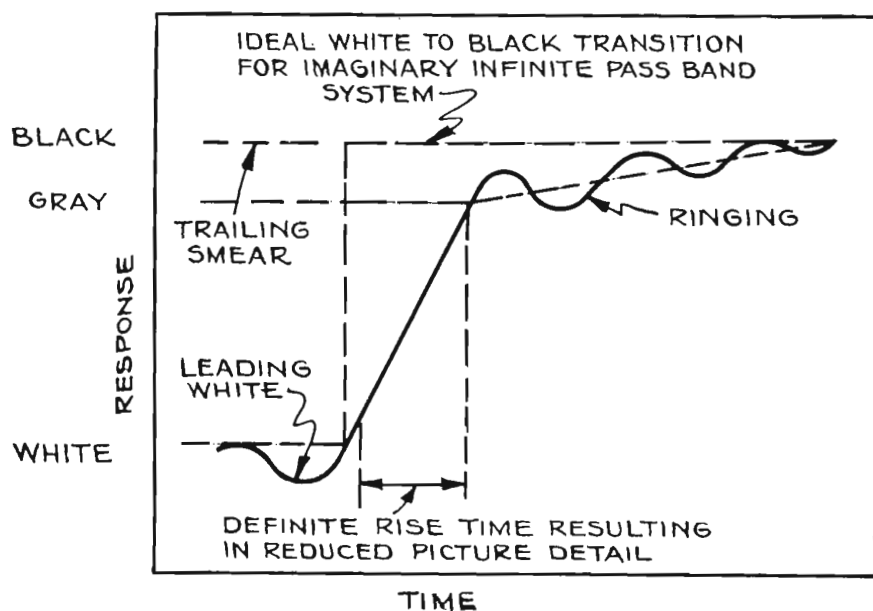

FIG. 5. Typical square wave response for FCC stipulated vestigial transmission characteristic showing forms of distortion associated with white to black transition.

HOW TO ADJUST LIMITER AMPLIFIERS

by **W. E. STEWART**

Manager, Broadcast Audio Engineering Section

The proper method of adjusting a limiter amplifier is a frequent subject of discussion when broadcast engineers get together. It is apparent from engaging in these conversations that there is little uniformity of practice in the field. Looking at the subject from the position of the design engineer, we feel that the following is the method that should be used. We know that the subject is controversial and would welcome any constructive comment that broadcast engineers can give us on the subject.

1. Determine the amount of compression that is desired when the transmitter is modulated 90%. Suppose a value of 6 db is chosen for this discussion.
2. Insert a steady tone of 400 or 1000 cycles into the limiter amplifier and adjust the input level until the limiter amplifier meter shows 6 db compression.
3. Adjust the output control of the limiter amplifier until the level at the transmitter terminals is just right for 90% modulation.
4. With the oscillator disconnected and a normal program going into the limiter amplifier, adjust the input control on the limiter amplifier until the meter indicates occasional limiting as high as 12 db.

Note—It should be remembered that a VU meter does not read the peaks of the program. If an output of +14 dbm is used to set up the amplifier with a steady tone, then a program level which gives peak readings of +4 on the VU meter may actually contain peaks as high as +14. This margin of 10 db is approximate and will change with the type of program material. Theoretically the above arrangement should be correct for approximately 12 db limiting of the program level with 95% modulation of the transmitter. Actually there will be some variation from this due to the fact that it is difficult to make the average program level run exactly right for this condition. Incoming programs which seldom give rise to greater than 3 db gain reduction are definitely low in average level and should be brought up manually at the limiter input or elsewhere ahead of the limiter. Those programs showing frequent gain reduction of more than 12 db are definitely too high and should be correspondingly reduced.

Note that a more or less arbitrary value of 6 db was chosen at 90% modulation.

The writer gratefully acknowledges the comment of Frank Marx, ABC; C. A. Rackey and J. L. Hathaway, NBC; and Charlie Singer and C. D. Samuelson of WOR. It should be pointed out, however, that the above material does not necessarily represent their exact thinking on the subject, since they all differ somewhat in their procedure.



HOW **RCA** **2-WAY** **RADIO**

**SAVES
TIME**

**SPEEDS
OPERATIONS**

**"STRETCHES"
EQUIPMENT**

... tells in non-technical language what 2-way radio is and what it does ... shows how it works. You'll see how management can know at all times what's going on because it has voice contact with roving crews and with men at remote locations.

... shows how RCA 2-way radio expedites materials handling, coordinates survey and construction projects, and eliminates aimless driving in tracking down trouble ... It reports how 2-way radio is used to route cars and trucks, to mobilize

repair crews fast, and to prevent disruption to production cycles.

... also covers the survey facilities offered by RCA to determine the 2-way radio system that best meets your business needs ... includes a digest of the FCC rules regulating industrial radio service ... reveals how to co-operate with industry's frequency allocation committees.

This brochure is yours for the asking. (In Canada, write: RCA Victor Limited, Montreal.)



RCA ENGINEERING PRODUCTS
Dept. R-150,
Camden, N. J.

Send me a free copy of "2-way Radio for Industry."

Name _____

Firm _____

Address _____

City _____ State _____



RADIO CORPORATION of AMERICA

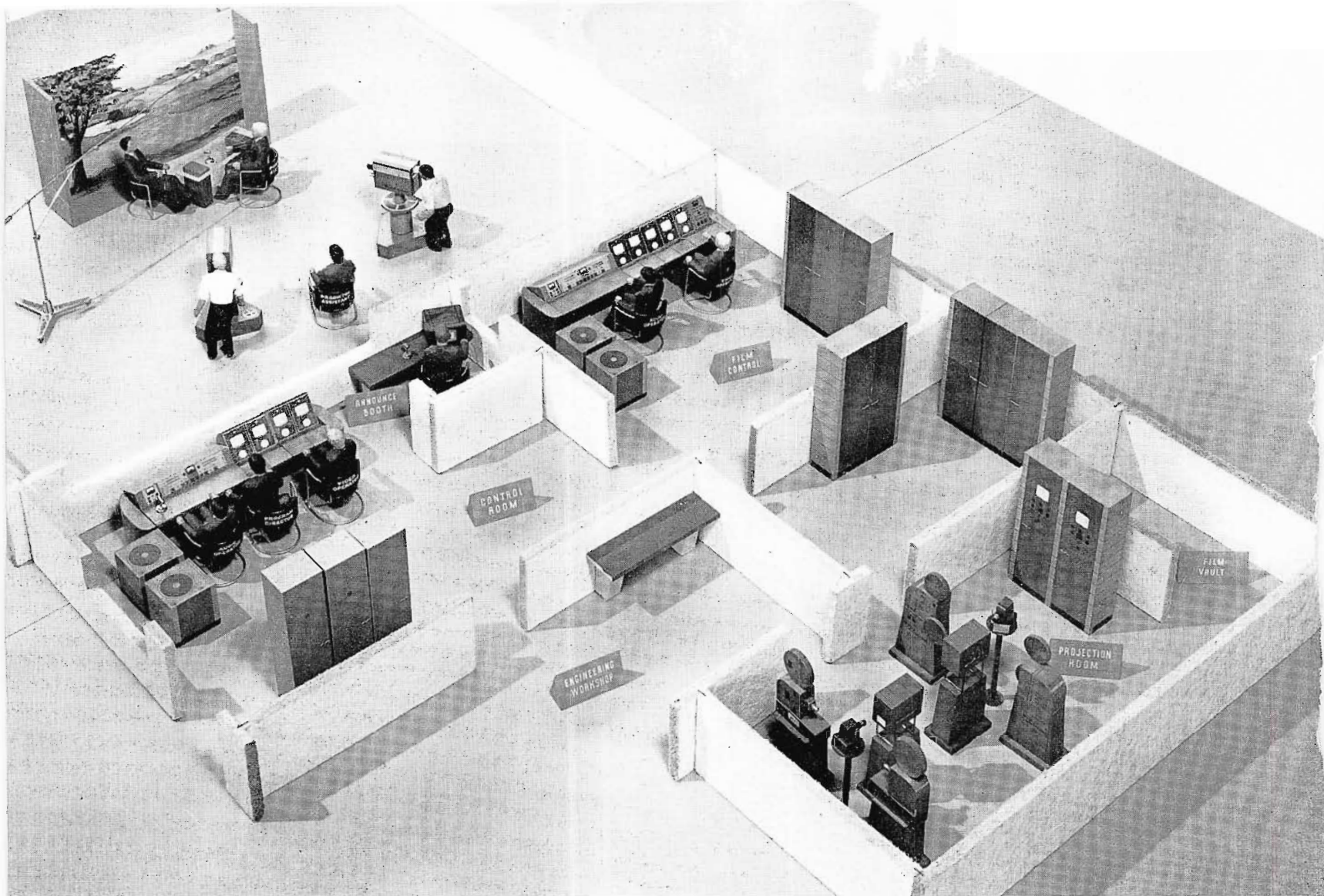

VIDEO RELAY SWITCHING LAYOUTS

Introduction

Television broadcasting has come into its own as a dynamic force in the entertainment and advertising world. Using the talents and techniques of its contemporaries in these fields, it offers an endless variety of program material ranging all the way from the facts of everyday news to the fancies of a classical ballet. Many stages, many performers, are needed to supply the needs of the industry and its audience of several million people.

Behind the scenes there is a complex maze of electronic equipment linking the television cameras to the transmitter. Pictures from many sources are combined, edited, and routed to the transmitter and network according to a split-second time schedule. During a "live" show, the viewer sees exactly the scene on which the camera is focused—there is no second medium of reproduction which may be redone, cut, or otherwise changed. Hence, any transi-

by
C. R. MONRO

Television Terminal Equip. Engineering

tion from one scene to the next or from one show to the succeeding show must be made with no gaps or unsightly splices, and with no chance for retakes or mistakes. Fleeting seconds ticked off on the clock mean the difference between a hit show with pace and mood and a show which drags and loses its audience. So, too, does the clock measure dollars of income from advertising spots as short as 10 seconds.

Planning for the Future

One can see, therefore, that continued success in such an activity must be based on a well-planned interconnection of the available facilities. This is the function of switching and distribution equipment in a television broadcasting plant—logically arranged and dependable to permit smooth

operation day after day, yet flexible so as to accommodate such requirements as rehearsals and new program material, and provide spare equipment for emergencies. The degree of versatility is, of course, dependent upon immediate program requirements and the budget set up in the beginning. Fortunately, the required video and audio units are available in the form of "building blocks," which, with a measure of planning beyond the present needs and budget, will serve as basic units to which additions may be made in the future.

General Requirements for Single Studio and Film

It is not due to the proverbial lazy man's dream that so many push buttons are found in a broadcasting system. Rather, it is a matter of necessity to provide means of control and organization over the many elements of program production and distribution. Many years of experience with sound broadcasting have demonstrated the merit of this statement.

Consider first the typical station shown in Fig. 1. Here are all the elements of a permanent installation, arranged in compact form. It is not the smallest station, nor is it a large one, but the studio facilities shown will handle the basic requirements for live talent shows and film presentation. In addition, switching and monitoring equipment is provided to handle the outgoing lines to the transmitter and network and also the incoming pictures from remote pickups, theatre shows, and network. The electronic units used to provide these facilities for both pictures and sound are only partly shown in the photograph. Many separate units are mounted in the cabinet racks, and in addition the required interconnecting power and signal cables are run below the floor in trenches and conduit.



FIG. 1 (opposite page). Model layout of a typical Television Broadcasting Station equipped to handle basic requirements.

FIG. 2 (above). Close-up view showing the Studio Control Room facilities.

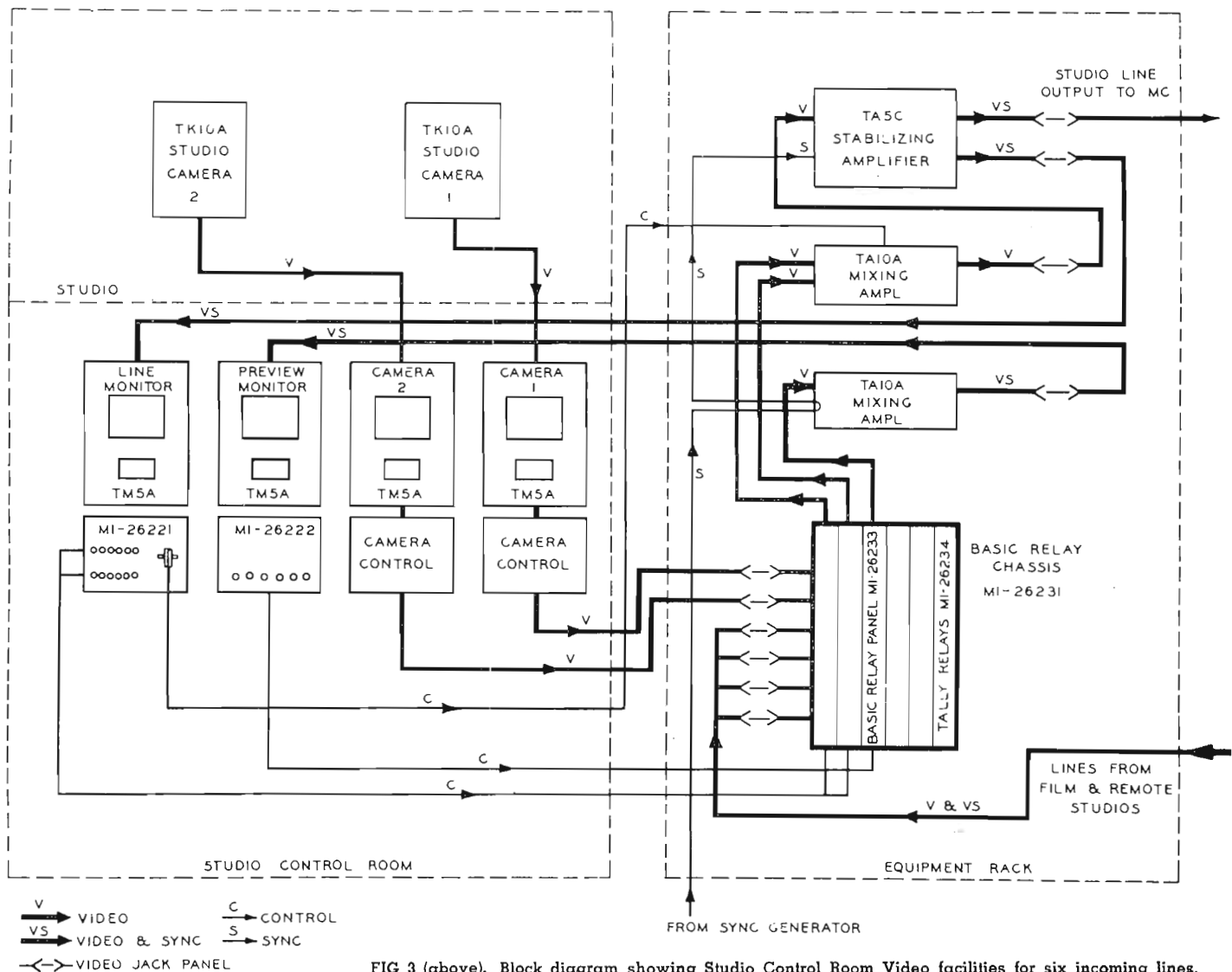

FIG. 3 (above). Block diagram showing Studio Control Room Video facilities for six incoming lines.

The Need for Remotely Controlled Video Relay Switching

To provide control over all these elements, two major tools are given to the operating personnel. First is monitoring equipment to see and hear the program material coming from the various sources. Second is switching equipment to permit selection of the right material at the proper time. Bringing all these loose ends into compact switchgear which may be located in a desk top soon becomes impossible due to the number of cables required for sufficient versatility of control.

Remote control is the answer—just as it is in AM radio broadcasting, power stations, railroad terminals, and many other applications. This way, the operators may be seated at consoles designed for comfort and convenience, while by means of push buttons, switching equipment is operated in its logical physical location in the plant.

It is the purpose of this article to discuss this “push-button” portion of the television broadcasting plant and to show some of the many variations possible in the layout of control consoles and video switching equipment. A previous article in BROADCAST NEWS, No. 58, March-April, 1950, has covered in detail the circuits and physical arrangement of the RCA TS-20A Video Switching System. This is itself a building block item because the system type number covers a wide assortment of switching and control units to meet the various specific needs. It is built around a relay switching circuit for video which is made in units of 6 inputs and 1 output with an electrical, self-latching arrangement to control timing. This matter of timing is a serious one in television switching since long breaks result in streaks, disturbing black screens, or even in some cases, loss of sync and a resultant roll-over or tear when the next picture comes on. In fact,

for camera switching, an overlap sequence is used to eliminate breaks completely. This, however, cannot be used in all applications since undesirable cross-ties during switching might occur. One solution is to reduce the gap to a minimum value. The RCA video switching relay banks offer a choice of an overlap or gap sequence approximately 1 millisecond in duration.

As the individual studios are described in detail further on in this article, one point should underlie the whole discussion. This is that we are not expounding the merits of one fixed layout—rather we recognize the infinite variety brought about in station design by each management's own individual considerations of budget, available building and floor space, and most important their own imagination and originality. It is intended to look backstage in some typical systems to illustrate reasons and ideas which will serve as a guide toward further uses and new applications.

FIG. 4 (below). Studio Control Room—showing use of Program Director's Console for larger layout for more than six inputs.

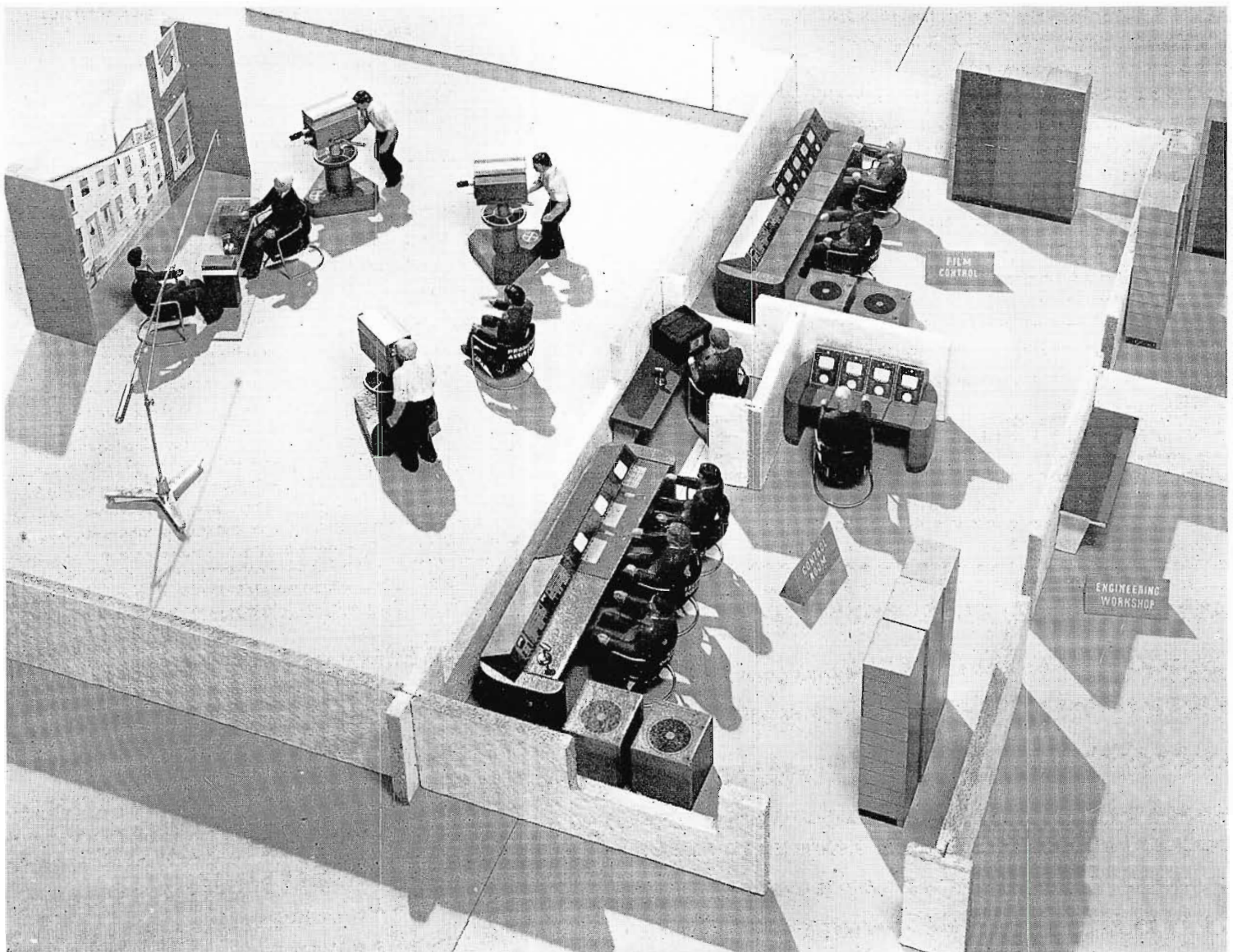
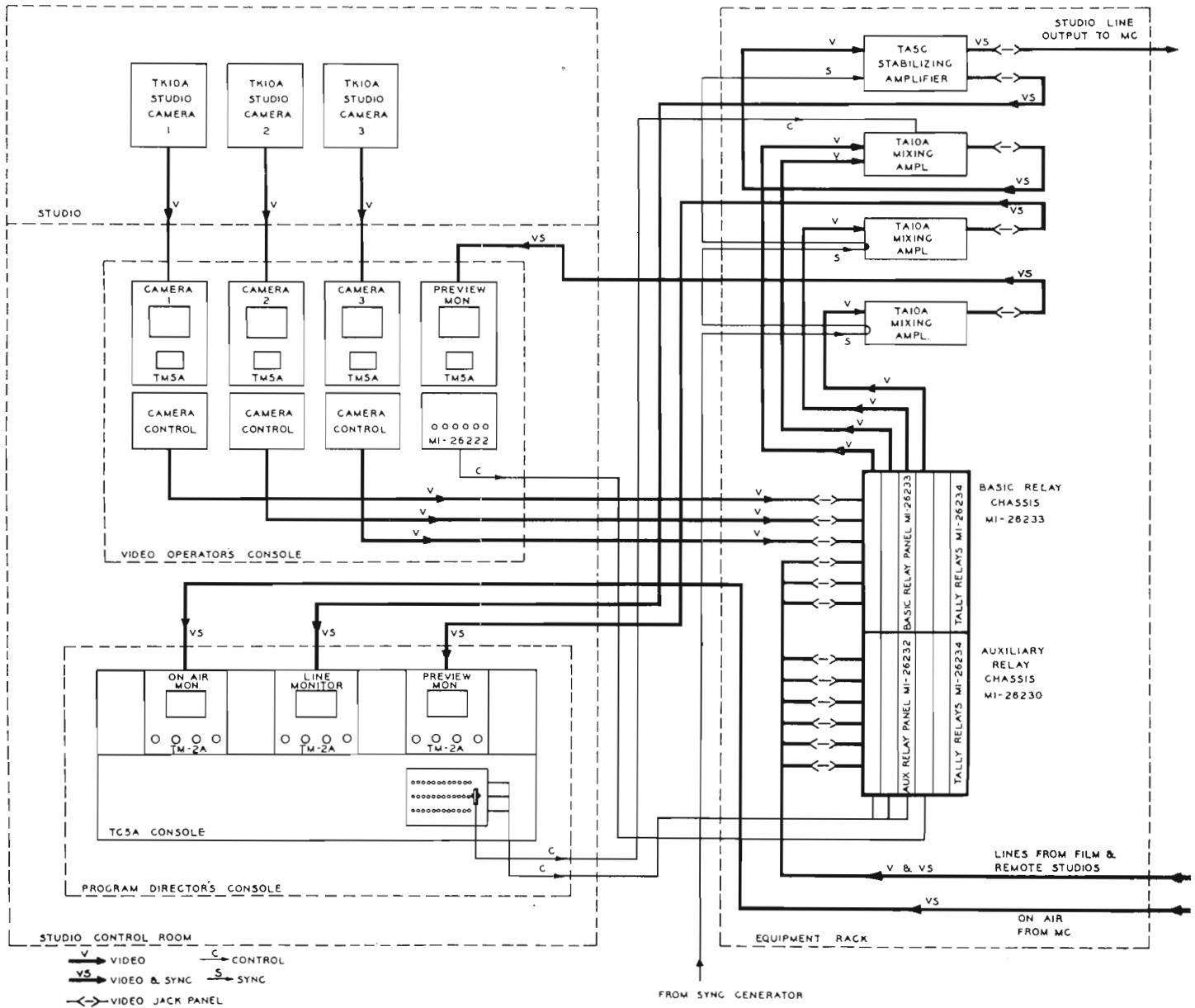

FIG. 5. Studio Control Room facilities of Fig 4, arranged with the Audio and Video Consoles on a raised platform.



FIG. 6. Block diagram of video facilities for layouts of Figs. 4 and 5 which employ the Program Console.



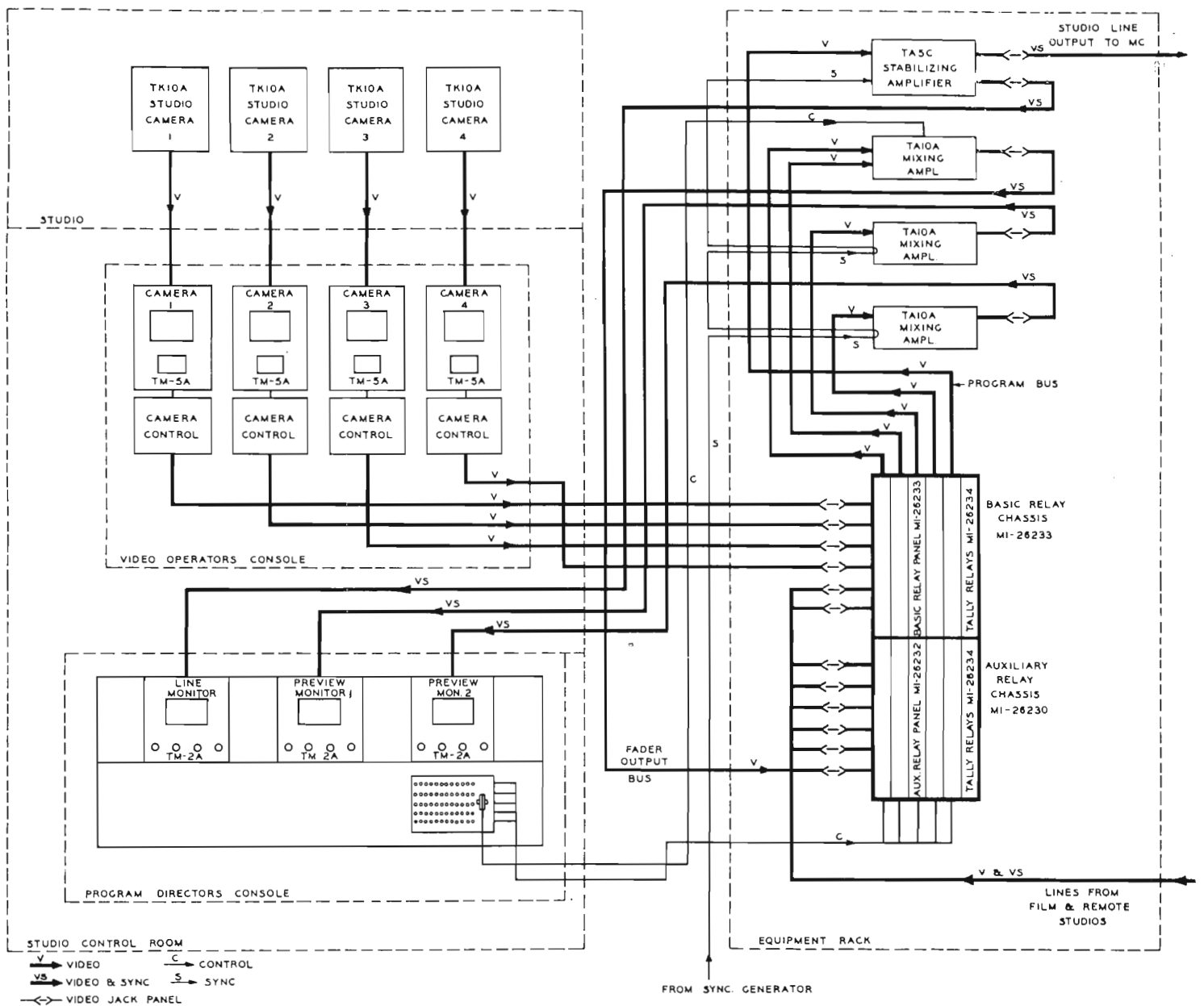

FIG. 7. Block diagram showing how the video facilities may be extended by adding the Program Console with Program Bus Output.

Studio Control Room Switching Facilities

Let us consider first the live talent studio control room facilities shown in Fig. 2. It is here that the program director finds himself the center of all activity. Following the script or continuity, he issues orders to each cameraman to set up each scene desired; then, having seen the pictures produced on monitors placed in easy view, he determines which is to be used and sent out on the air. To control the transition between scenes or to produce superposition and dissolve effects, switching and fading equipment is available to him in the form of push buttons and fader levers. Depending upon the size and operating personnel of the particular station or network center, the program director may or may not actually operate this console. In some cases a technical director performs this

function, the two sitting at the same desk so as to see all the monitors.

The switching equipment shown in Fig. 3 provides for six incoming lines which would include the cameras in the studio, direct lines to the film cameras for slides and movie portions of the show, and other lines to remote inputs if pictures from other studios or outside the station are to be used. The console is arranged so as to permit viewing both camera pictures on their own camera control monitors and the line output of the studio on another monitor. It is made up of standard RCA camera control and monitor console sections. The actual push buttons and fader unit mount in one of the console housings with the line monitor. In the diagram and illustrations, an improvement in operation has been effected by the addition of a third

panel of relays on the relay bank to feed a separate monitor which may be switched to any of the inputs. This is termed the preview monitor since it permits viewing the other incoming pictures before switching them on the air.

For Larger Studies—More Than 6 Inputs

For a larger studio, built to handle full scale dramatic plays or musical revues, more cameras are used in the studio itself and the inserted portions from film, slides, or other studios might easily require more than six inputs. Also, more studio monitors are required in the control room to keep track of the additional activity. For this the large RCA TC-5A Program Director's Console is available, into which a twelve-input switching control panel is built, and

which may contain as many as five RCA TM-1A Program Monitors.

Fig. 4 illustrates the basic elements of this larger layout with three monitors in the director's console, to cover "On the Air," "Line," and "Preview." The console itself may be located against the studio window as shown, or on a raised platform behind the camera controls as in Fig. 5, so as to permit the program and technical directors to see their own monitors, the camera monitors, and also into the studio. The video block diagram for these layouts appears in Fig. 6. Note that by the addition of an auxiliary relay chassis, the number of inputs in the video switching rack has been extended to 12. Also, the video operator has been provided with a preview monitor by the addition of another panel of relays and a sync mixing amplifier. A further extension of these control facilities which has found increasing use recently is the addition of a "program bus" row of push buttons to the control panel as shown in Fig. 7. This permits previewing of the output of the fader channel since any input may be put directly on the air through the

program bus or sent through the fader channel for special picture effects. Also, a different arrangement of monitors is shown. The program console now contains two preview monitors to increase its usefulness, and four studio cameras are connected to the video operator's console.

TS-20A Switching Includes Film Studios

Although the preceding discussion was based on a live talent studio, the same facilities are equally useful for a film studio which contains several cameras and projectors. Similarly, a large network center fed from several remote points such as theaters and sports arenas may also use a set of these control facilities, handling the complete station programming of shows and commercials without tying up master control facilities.

Obviously there are endless variations possible, the illustrations given here serving only as examples. In Fig. 1, the video console shown in the film control room is arranged to handle the two film cameras and also the master control facilities, which will be described later. In Fig. 8, the film studio is located on a different floor of the

building, with its control room adjacent to it. Or, the film control could be combined with studio facilities in a single control room arrangement. With sufficient monitoring facilities, it is even possible to locate the studio control room separately so as to eliminate the usual connecting window area and so make more floor area available in the studio. The basic reason for all of this should be kept in mind since it is actually the key to the much desired "new and different" operation. Production people are constantly searching for new ideas of presentation and they must, wherever practical, be provided with the necessary facilities. The need becomes obvious for smooth-running operation during all the cutting and trimming that occurs in the building of a show. All of this must go on while the show unfolds; there is no time for retakes or changes because the audience is literally looking over your shoulder.

TS-20A Relay Switching for Master Control

The live talent and film studio control facilities do not comprise the only applica-

FIG. 8 (below). Typical Television Broadcasting Station layout in which facilities are located on two floors.

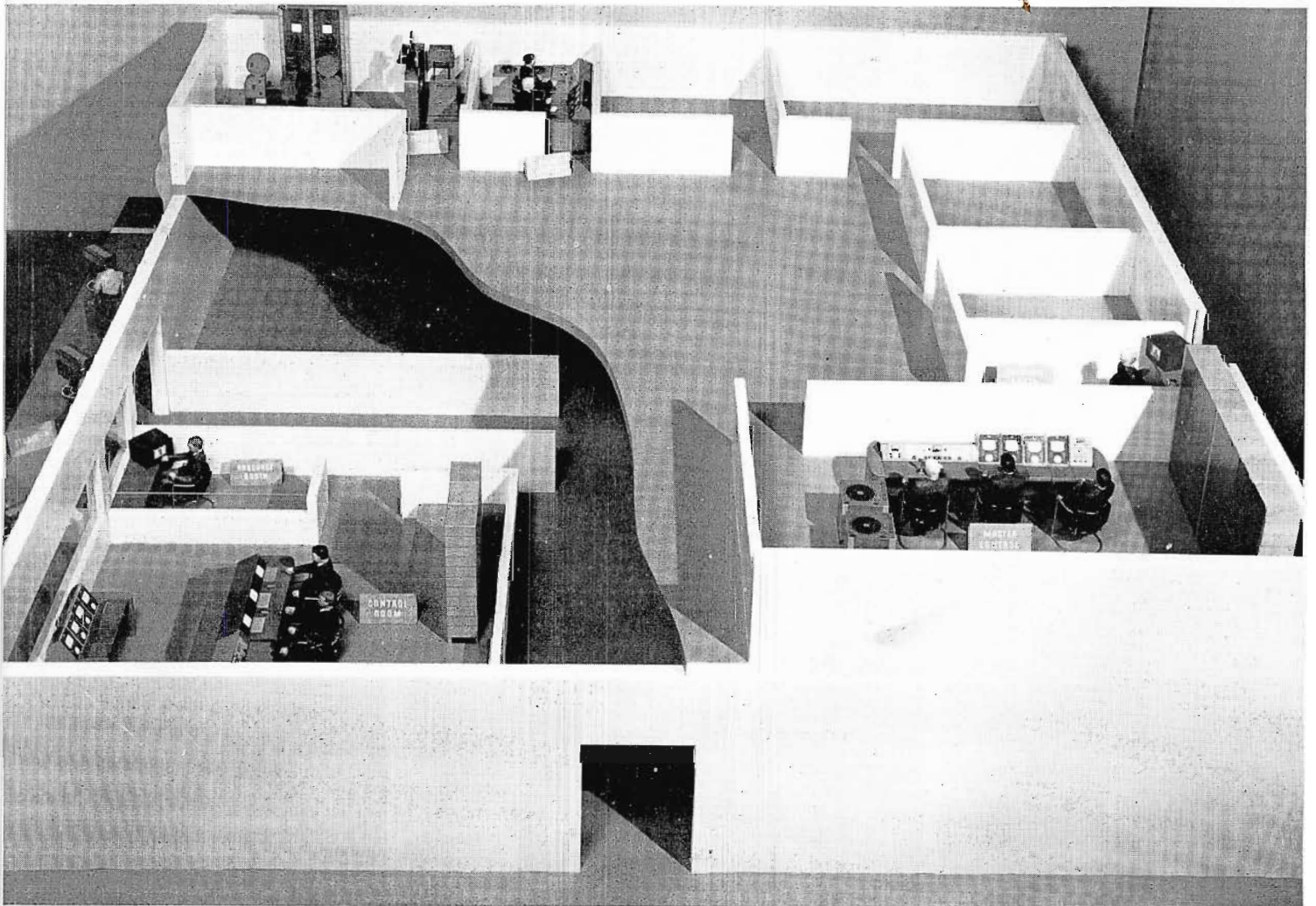

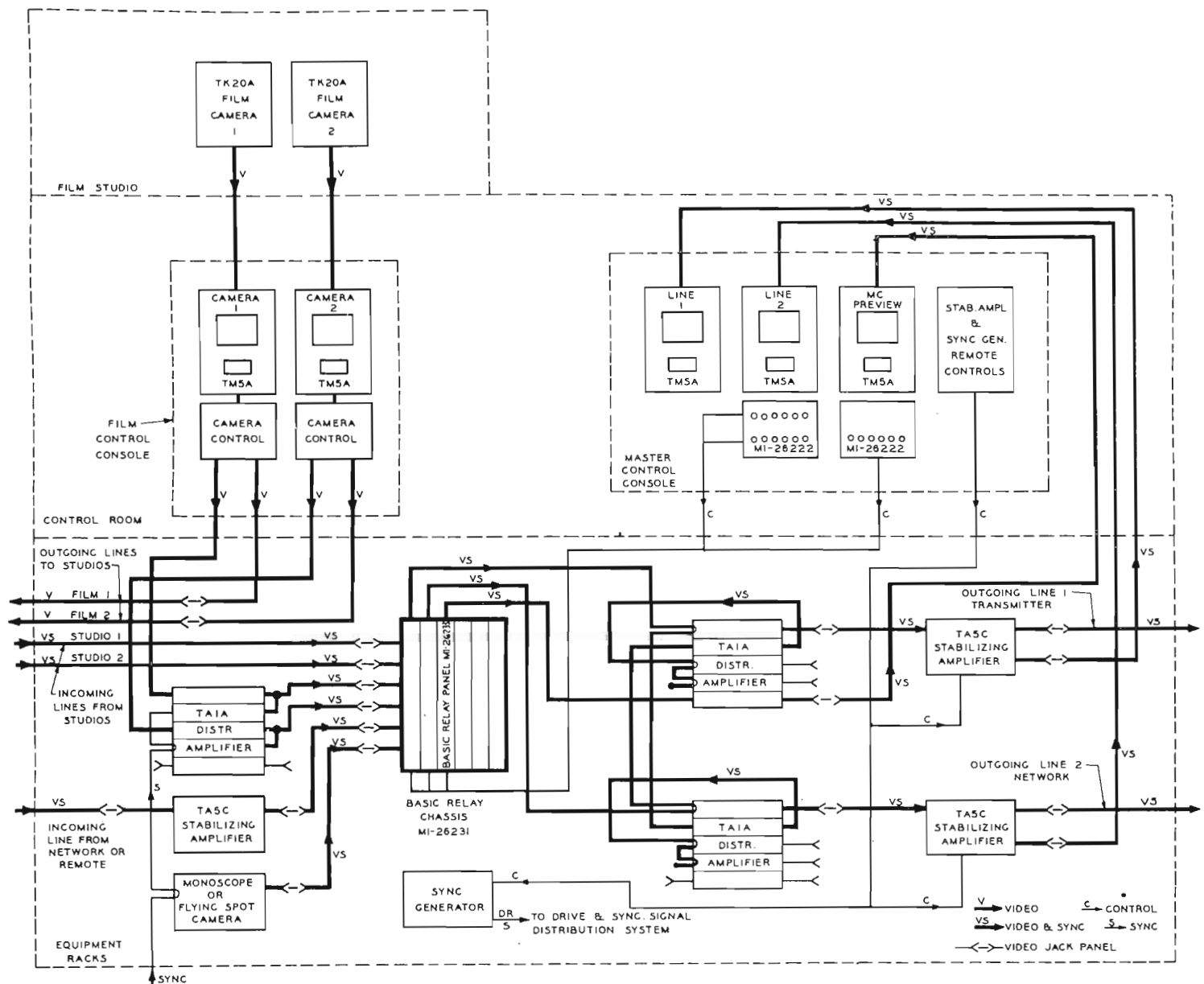

FIG. 9 (above). Block diagram showing Master Control facilities made up of standard console sections.

tion of video relay switching in a television plant. In Master Control, program material from all the available sources, whether studios or remotes, is chosen at the proper time and sent out to the transmitter or network. Operating schedules call for split-second timing with no errors and a minimum of delay in meeting emergency or unusual requirements as for rehearsals and special client showings.

Here again, video relay switching finds its place in providing a flexible system. The actual switching panels used differ widely, however, in following each different station's operating philosophy. In Fig. 1, the master control monitoring and switching facilities are shown combined with film control consoles. In Fig. 8, the master control room is in a different part of the building. The block diagram shown in Fig. 9 illustrates the typical connections for these

facilities using standard console sections and master monitors. Appropriate push-button panels are mounted in the consoles.

Audio-Video Switching

Many are now using "tied-in" audio switching in which audio channel relays are operated from the video system or just the opposite in which an audio console and its associated relays have provisions for operating the video relay bays. A further variation, is provision for either separate or tied-in operation. Control circuits for one such arrangement are shown in Fig. 10. In this circuit the audio relays in a standard RCA BCS-1A Master Control Audio Console are switched from their own push buttons to the tally contacts on the video relays in the TS-20A Relay Switching System.

Although the timing requirements for transfer time are quite different in the two

systems, the RCA video switching relay strips fit in without change. It is the usual practice to provide a gap switching sequence in the audio channels as a part of the relay interlocking circuits which is very long compared to the value tolerable for video. When operated from such a system, however, the video relays transfer at their own rapid rate independently of the audio timing. In the opposite arrangement, audio relays operated from the video channels should be provided with "operate" delay coils to restore the usual audio gap.

Preset Switching

A considerable improvement in operating ease and accuracy may be brought about by the use of a "preset" switching system. With this arrangement, the rotary or push-button switch usually used for channel selection is normally dead and may then be set up for the next channel ar-

rangement to be put on the air. Then, at the proper instant, one trip button will cause one or several channels to transfer to the new "preset" schedule. One type of preset control circuit is shown in Fig. 11. Only one outgoing channel is shown here; several are normally used side-by-side. For operation of individual channels the preset switch is set to the desired incoming channel, then the local operate button is pushed at the proper instant. For master operation of several channels simultaneously, the channels to be used are set up and then switched to master position. Then, the master operate button will transfer all the channels at the same time.

A similar circuit, extended to include control of an audio switching system is shown in Fig. 12. Normally, the audio and video relays are both operated from the selector decks of the video preset switch. However, complete interlocking circuits for the audio relays are included so they may be operated separately or in conjunction with the video relays either on the same or different incoming channels. An additional feature is a form of "double" preset in which the outgoing channel trip circuits may be connected to either of two master busses. This way, two program arrangements may be preset and then put on the air in sequence. For instance, during a program change, a local commercial introducing a certain show might be picked up on the transmitter line using the Master Preset A circuit; then, without disturbing the transmitter feed, the network line would be switched to the same program at the conclusion of the announcement by operating the Master B circuit.

Another form of "double preset" that has been considered uses two Master Preset busses which operate the input selection circuits for each output channel. Two preset switches are provided for each outgoing channel. First, one choice of input, then a second choice, may be put on the outgoing line in sequence. This, of course, applies either to one or several outgoing channels as determined by "Local-Master" switches. Practical use of such a circuit probably would only occur in a station operating schedule which calls for the handling of short announcements during station break by Master Control. Normally, such activity in Master Control is not desirable, particularly in a large plant, and may be avoided by adding these short program units to the beginning or end of regular, long shows.

As mentioned before, the video relays may also be operated from an audio preset system of one of the well-known types

used in standard broadcasting. Fig. 13 extends the flexibility of Preset Master Control still further—in that direct switching is possible without the "preset" then "trip" operation required by the previous circuits. The push-button leads from the video and audio relays are transferred from one "on-the-air" panel of push buttons to another "preset" panel. An on-off step relay circuit is used to accomplish this transfer and is actuated by "Local Operate" or "Master" push buttons as desired. The audio and video preset systems employ separate push buttons so that they may be operated either independently or tied together. When a push-button panel is "on the air," direct switching may be done without the additional manual operation of one of the preset trip buttons. This proves very useful for emergency and test conditions and may also be used for such a program function as insertion of local commercials in a remotely originated show.

There is another approach to allowing master control to handle program functions particularly for "spot" commercials between programs or announcements during a remotely originated show. With the use of the RCA "Genlock" (BROADCAST NEWS No. 58, March-April 1950) to synchronize local and remote signals, the fader mechanism used in the studio control room is found useful in master control to permit studio type picture effects without requiring extra studio facilities or personnel. An arrangement similar to Fig. 3 for studios may be used.

Studio Control of Master Switching

So far, we have considered the studio control room and the master control room as being entirely separate, at least operationally, if not physically. This is not essential as illustrated in Fig. 14 by a scheme of optional control from either of two studios, of the relay bay which feeds outgoing

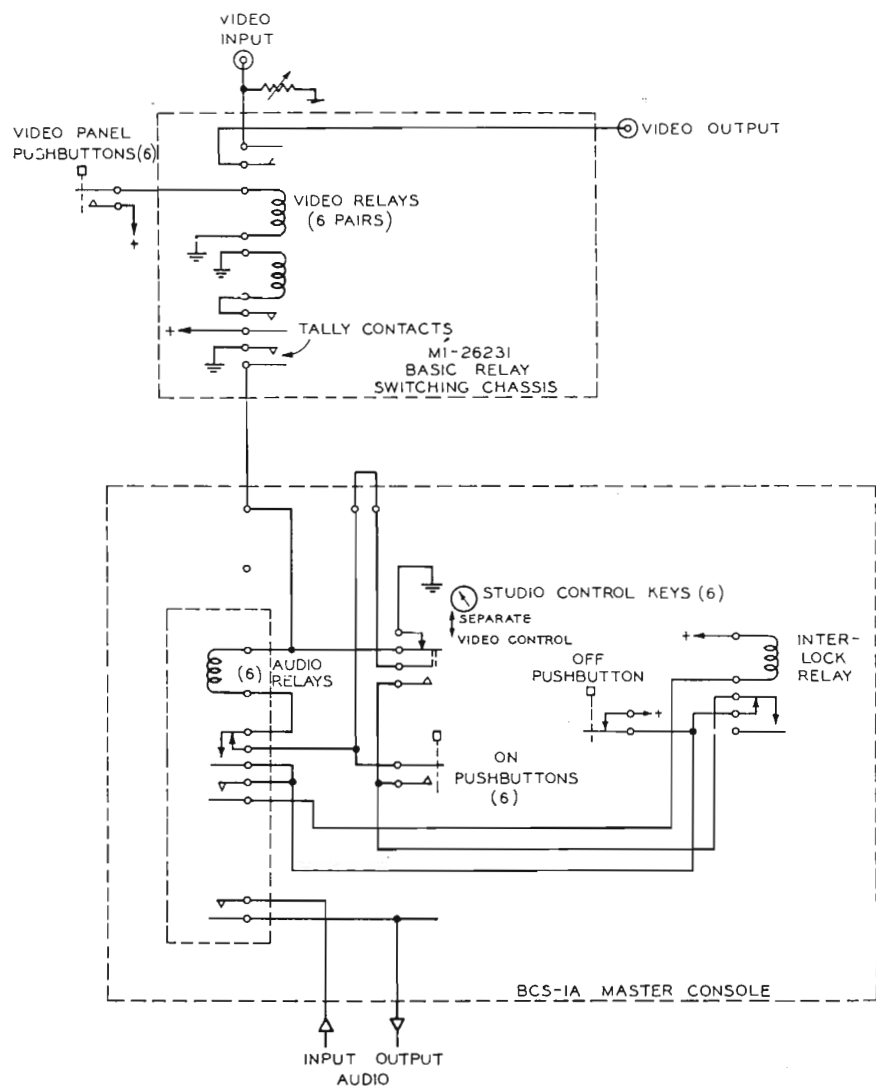

FIG. 10. Simplified schematic diagram showing control circuits for Audio/Video Master Control Switching. (Note in diagram that one relay or pair of contacts may actually be two or more in an interlocking circuit or in several identical circuits.)

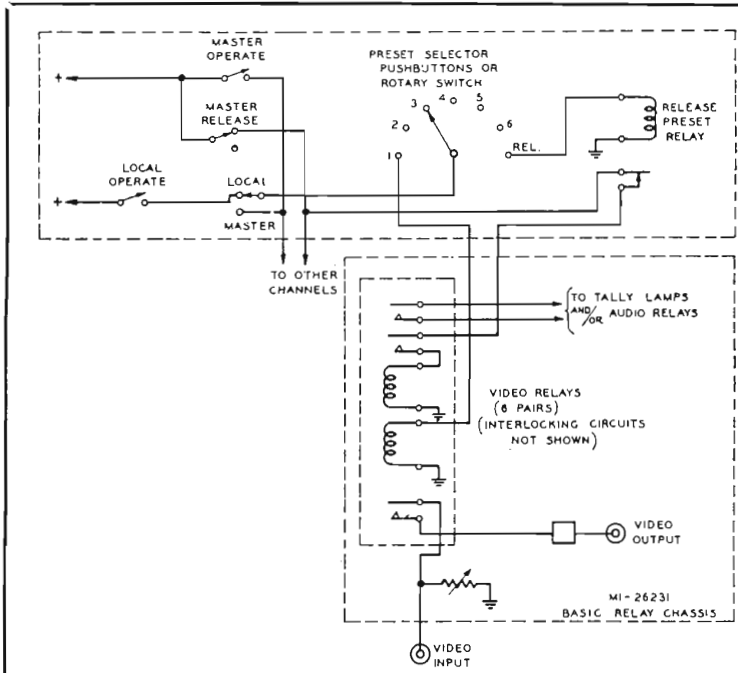

FIG. 11. Simplified diagram showing Preset Master Control Video Switching.

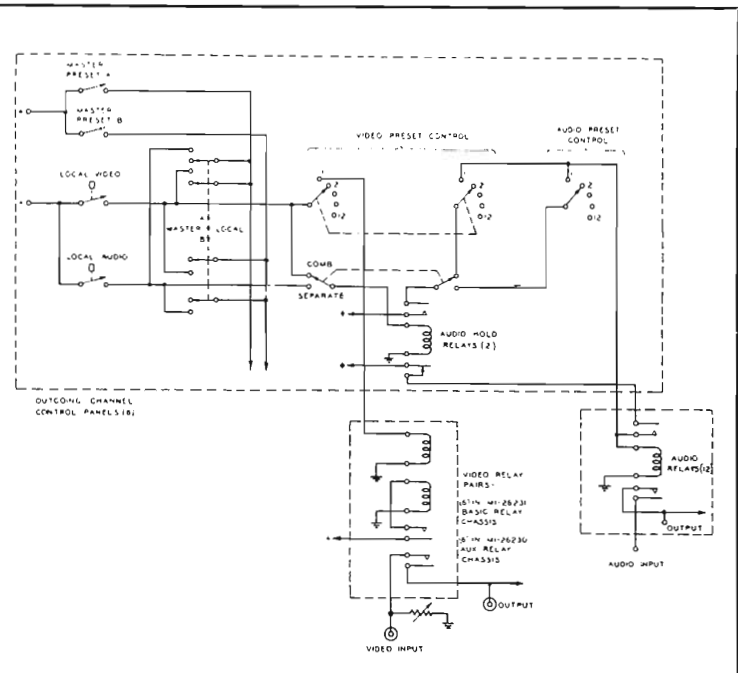
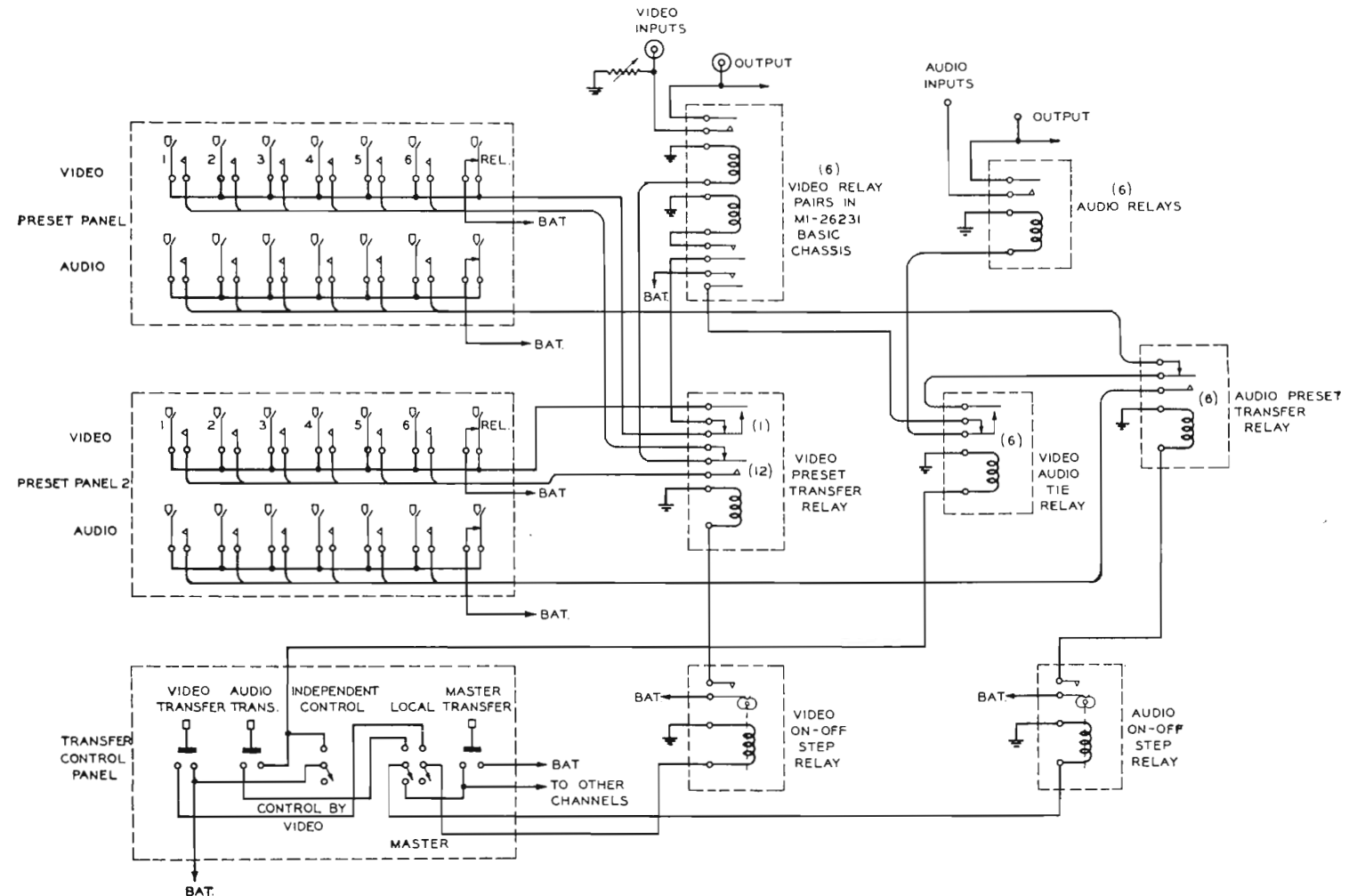

FIG. 12. Simplified diagram—Preset Audio/Video Master Control Switching used at KECA, Los Angeles, Calif.

FIG. 13 (below). Simplified diagram showing Preset Audio/Video Master Control Switching used at Station WOR-TV, New York.

FIG. 14. (opposite page). Simplified diagram illustrating a two-studio Control arrangement of Master Control Video Switching.



lines to the transmitter and network. The switching panels are duplicated in each studio and transfer of controls is made according to the program schedule of each studio. This circuit uses remotely controlled relays for the transfer operation which are interlocked to prevent accidental mix-ups and which operate "on-the-air" and "ready" lights in each studio.

In many cases extra outputs are available in the standard video relay bays. These are often put to use to feed preview or rack monitors and also are available as emergency program channels, and for house monitoring lines.

The future will bring even more uses and variations for remote control switching. In the large network centers even

present patch-cord arrangements may be replaced with push-button or dial-controlled switching units as more and more program, rehearsal, and test traffic must be handled.

Conclusion

In the preceding illustrations, several video relay switching setups have been described. These represent but a few of the many TV switching problems which are easily solved by use of the RCA TS-20 Relay System in combination with other catalog items readily available. As such, this equipment does for TV master or studio control what Audio Relay Systems have done for aural broadcasting with parallel advantages such as instant, push-button switching, unlimited flexibility, centraliza-

tion of control and operations, and provision for long range future planning. These advantages of Video Relay Switching are equally important to existing TV installations or to new stations. In conclusion, the design of Video Relay Equipment has provided a basic element which may be used with companion RCA TV studio equipment to permit full and efficient utilization of equipment, as well as the smooth presentation of diversified program material.

Acknowledgment

Credit is due to J. H. Roe, W. E. Tucker, L. E. Anderson, and to other members of the Television Terminal Equipment Engineering Section who assisted in the preparation and presentation of this article.

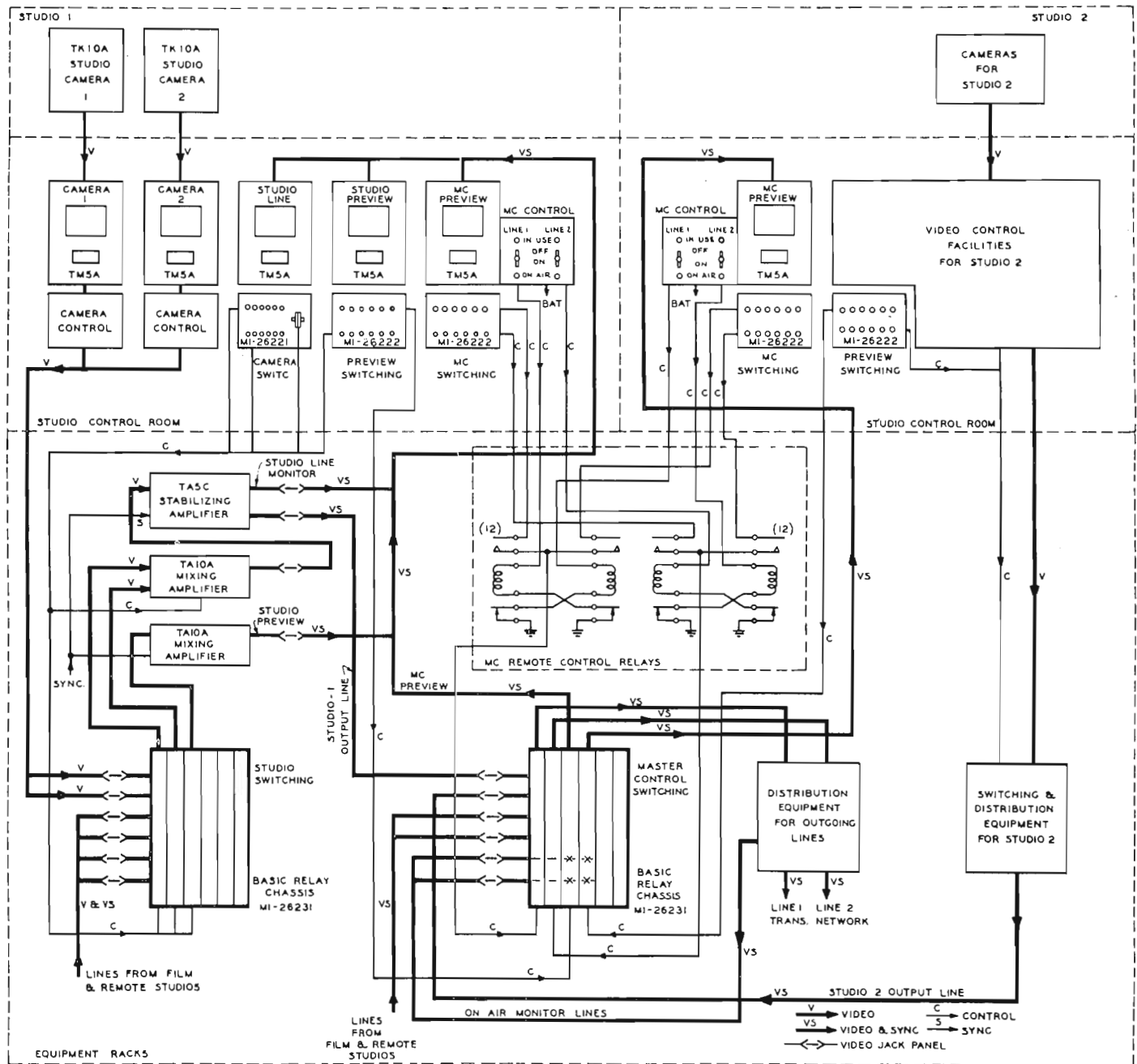

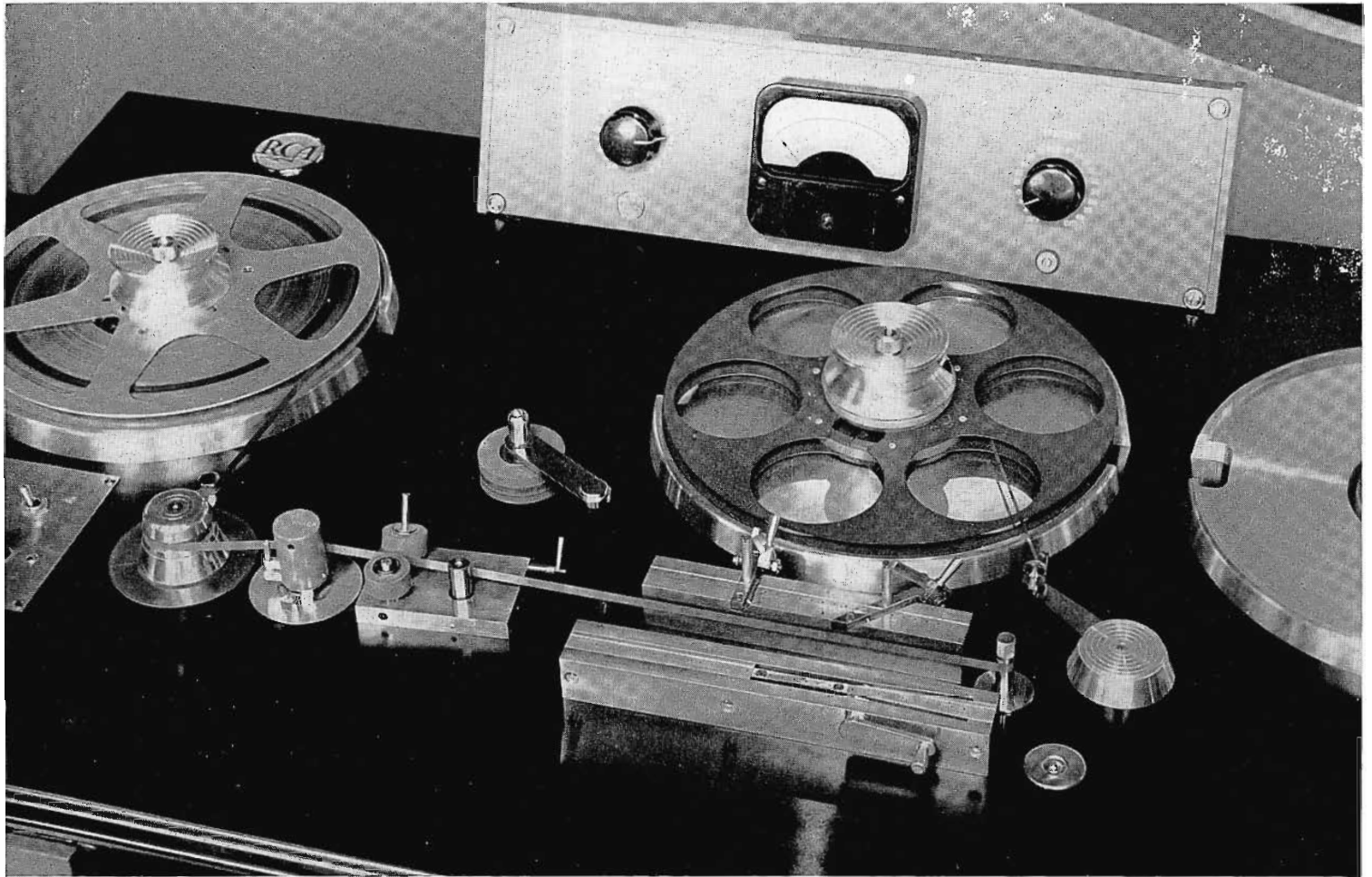

FIG. 1. Closeup view of the Magnetic Tape Editing Machine. Editing Accessories, and machine components are shown left to right: Control Panel, Stabilizer, Reproducing Head, Tape Marker, Capstan Tape Cutting and Splicing Bars, Vacuum System Switch and one of reel drive tape take-up arms.

AN EDITING MACHINE FOR MAGNETIC TAPE RECORDING

Introduction

The need for an instrument designed to facilitate the editing and playback of magnetic tape recordings has become apparent with the rapidly increasing use of tape as a recording medium. Such a machine should provide a rapid, yet simple means of spotting, marking, cutting and splicing the tape as well as incorporating all those features to be found in a professional quality tape recording mechanism.

Design Features

The ultimate performance of an editing machine depends, to a large extent, upon the quality of its tape handling facilities. Consequently, a considerable amount of time was spent in the design and devel-

by **D. C. YARNES**
Audio Engineering Section

opment of a drive system providing performance equivalent to that of a professional tape recorder. Rapid starting and stopping of the tape as well as fast rewinding action is essential for accuracy and speed in editing magnetic tape. Excellent performance in these respects has been obtained by driving each reel with its own torque motor and providing fast acting solenoid-operated braking mechanism on each reel drive.

Three reel drive mechanisms are shown on the top panel in Fig. 1. The left hand reel is used to supply program material to be edited, while the other two reels are

used to take up the edited tape. The control circuits are so arranged that edited or discarded tape may be either run into a basket or wound on either reel as required providing a flexible arrangement for editing operations. Normally, the center reel is used for the edited program while the right hand reel is used to hold the unwanted tape.

Using an N.A.B. standard $10\frac{1}{2}$ -inch reel as a basis for measurement, the editor will completely rewind 2400 feet of tape in one minute if started from a dead stop. Equally fast stopping and starting is available so that a complete stop from playing speed is made in approximately .1 of a second and a stopped tape can be started to wow-free speed in approximately .5 second.

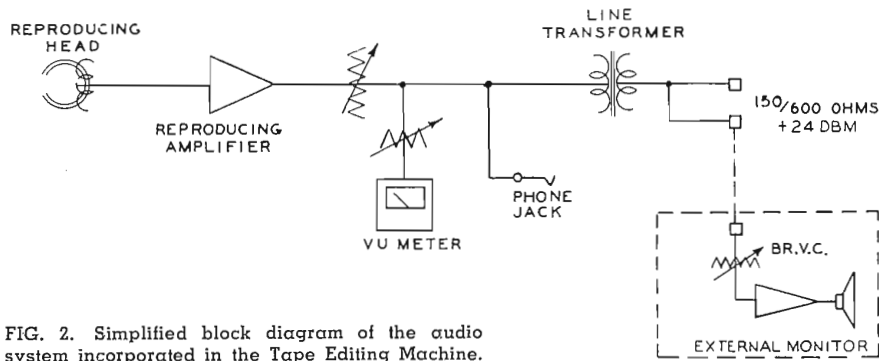

FIG. 2. Simplified block diagram of the audio system incorporated in the Tape Editing Machine.

Experience has shown that accuracy of timing and the high rewinding speeds attained by the editing machine necessitate the use of a positive locking reel retaining knob on each reel drive. The knob, shown on top of the reel drives in Fig. 3, meets all requirements without decreasing editing speed or ease of operation in any way. It is equipped with a retaining device that locks when the knob is pushed over the drive shaft. A finger-tip operated release provides an instantaneous opening of the locking device to permit a rapid change in reels. The knob is designed to accommodate all standard reels by using its base

as a hub for the standard 10½-inch reel and by setting it on top of the 7-inch reel. A special retaining ring in the base of the knob allows the 10½-inch N.A.B. standard reels to be removed or pressed on over the knob without necessitating removal of the knob itself.

Additional protection against accidental release or slippage over a long period of operation is provided by a knurled locking bushing which permanently locks the knob to the drive shaft.

Synchronous operation at tape speeds of 7.5 and 15 inches per second is obtained by driving the capstan with a hysteresis-

synchronous motor through a cogged belt and gear arrangement. High stability with a resulting low percentage of wow and flutter is obtained through the use of a high inertia system properly stabilized and operating continuously. Timing accuracy is such that 30 minutes of playing time is within $\pm 2\frac{1}{2}$ seconds of synchronous tape speed.

Control System

The control system, located in the lower left hand corner of the motor board, as shown in Fig. 3, is built around a three position push-button switch, by means of which the operator selects the required mode of operation.

The tape is started in Fast Forward or Rewind by pushing the designated button and stopped by the Play button. Switching from Rewind to Fast Forward or vice versa, is accomplished by pushing the button for the desired operation.

The tape is played back by pushing the Play button and manually lowering the capstan pressure roller. Raising the roller stops the tape.



FIG. 3. Photo showing an overall front view of the Console Magnetic Tape Editing Machine. Note foot rest and sequence type foot switch located in the foot ramp.



FIG. 4. End view of the Editing Machine illustrating how removable end panels make the amplifier easily accessible.

Various interlocks, at the same time, act in conjunction with the selector switch to prevent operation with improper tape threading, as well as to stop the reel drives in case of tape breakage.

Each of the two take-up reel drives is provided with an independent control circuit actuated by its own tape take-up arm. In addition, the control system is so arranged that the editor, if he wishes to gain the time required for threading the tape into the take-up reel, may run the discarded tape into a basket by putting the machine in "Play" position and allowing the capstan to pull the tape from the supply reel.

Tape speed is easily changed from $7\frac{1}{2}$ to 15 inches per second by operating a toggle switch conveniently located on the control panel. A relay controlled speed compensation in the Reproducing Ampli-

fier is also actuated by the speed change switch making possible a rapid change in tape speed with a minimum of operational effort.

Threading the tape and manual operation of the reels for spotting the tape in editing are greatly facilitated by a brake release on the reel drive mechanism. This release is effected by a sequence type foot switch located in a foot ramp, shown in Fig. 3, which energizes the brake solenoids by means of a relay. This operation is entirely separated from the normal control circuits, allowing the operator to release the brakes at any time regardless of the position of the tape or control switching at that instant.

Audio System

The audio system shown in Fig. 2 consists of a Reproducing Head, Reproducing

Amplifier, Amplifier Power Supply, Program attenuator and provision for speaker or headset monitoring.

The plug-in Reproducing Head has been designed to combine professional quality reproduction with ease of adjustment. A single screw azimuth control and a simple means of rotating the head enable the operator to obtain optimum performance with a minimum of adjustment.

The output of the Reproducing Amplifier is supplied to two 150/600-ohm monitoring receptacles at the back of the equipment through a Bridged Tee attenuator. A maximum output of +24 dbm at maximum recording level is available for supplying an external monitoring amplifier or magnetic tape recording equipment.

A VU meter, with a variable attenuator, and head phone jacks have been supplied to furnish local monitoring as desired by the operator.

Marking the Tape

The time consuming and tedious task of marking, cutting and splicing the tape has been reduced to a rapid process by three accessories that have been added to the tape editor.

The tape marking device is shown located between the Reproducing Head and the capstan shaft in Fig. 1. It is composed of a rubber pinch roller and a rubber marking roller between which the tape is passed. The marker is actuated by releasing the pinch roller and drawing the tape manually between the two rollers. The marking roller measures the tape and makes a pin prick coinciding to the center of the Reproducing Head, allowing the operator to make an accurate cut in the recorded tape. Increased editing speed is obtained in practice by marking both ends of a section to be cut before performing any cutting or splicing operations. Finger-tip control of both the release and return of the pinch roller allows the operator full use of both hands while carrying on the marking operation at the same time, increasing the speed and improving the accuracy of the marking operation.

Cutting and Splicing

The tape cutting bar is located near the center of the motor board above the tape path as shown in Fig. 1. It is composed of two hollow ground stainless steel cutting knives mounted on a single bar. Either a 45 or 90 degree cut can be made at the

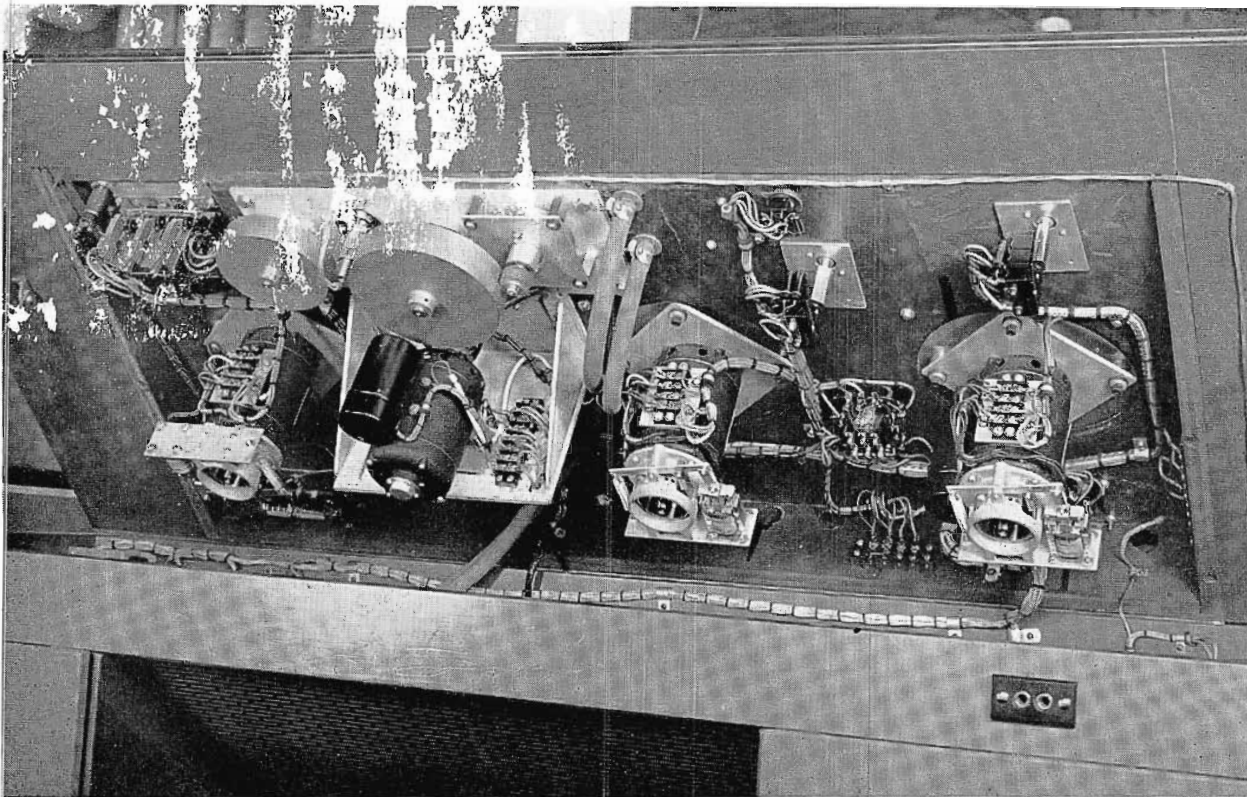

FIG. 5. The entire motor board may be raised by means of a hinged panel to make the control mechanism and wiring accessible.

option of the operator providing the versatility demanded by the normal editing operations, while complete freedom of hands and greatly increased cutting speed are facilitated by a special vacuum system that holds the tape firmly to the cutting bar.

The tape splicing bar, shown in Fig. 1 below the tape cutting bar, completes the special accessories on the editing machine. It is composed of a single bar upon which a pair of spring loaded stainless steel knives are mounted. The tape is held to the block in the proper position for splicing by the vacuum system discussed above, while the splice is made.

The knives are then operated by a single crank which causes them to cut the tape splice in the generally accepted "hour-glass" figure.

This editing machine was the result of joint efforts by the NBC and RCA engineers to design a tool for those engaged in the previously tedious and time-consuming task of editing magnetic tape. Its features incorporate the performance desired by tape editors as well as providing the producer or sponsor of a transcribed program with a high quality monitoring signal comparable to that of the final transcribed program.

**IN THE
ACT—**



EDDIE CANTOR, "COLGATE COMEDY HOUR," NBC

**—without hiding the actor
RCA's "STARMAKER"®**

... a ribbon-pressure microphone that is so slim ... so skillfully styled ... so unobtrusive ... you must look twice to see it.

Despite its slim construction, the STARMAKER meets the exacting quality standards of other RCA professional Broadcast microphones. Pick-up is non-directional. Frequency response is substantially uniform, 50 to 15,000 cps. It is free from wind rumble and air blast ...

and virtually impervious to mechanical shock.

The STARMAKER fits any standard microphone stand ... can be used in place of any RCA microphone. *No extra attachments needed.*

For delivery information call your RCA Broadcast Sales Engineer, or write: Dept. Q-7, RCA Engineering Products, Camden, N. J. (In Canada write: RCA VICTOR Limited, Montreal.)



RADIO CORPORATION of AMERICA

New Era in Video

-via **REMOTE**

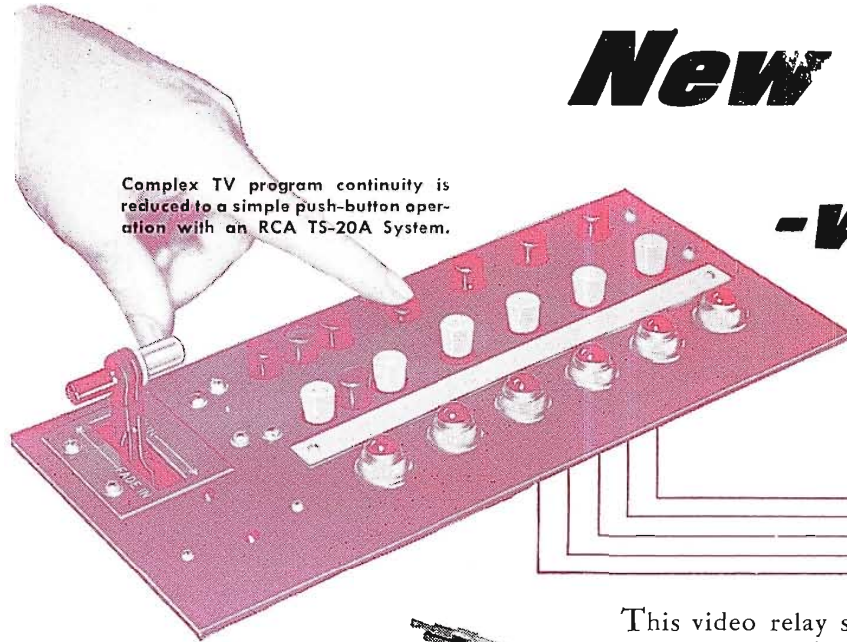

Complex TV program continuity is reduced to a simple push-button operation with an RCA TS-20A System.

This Relay Switching System does what RCA's Audio Relay Systems have

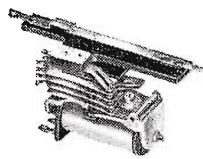

This video relay system removes all switching restrictions from equipment operations. It imposes no limitation on equipment installation—no matter where you set up your units. It provides unlimited flexibility—enables you to add facilities as your station grows, *without losing a penny's worth of your original equipment investment.*

Actual switching in the RCA TS-20A system is done by d-c operated relays *located in the video line itself!* Designed by RCA for this special service, these relays are controlled by

simple d-c lines from any point you choose. No expensive coaxial line required to and from control points. No extra cable connectors needed. You can rack-mount the relays wherever you want them. You can set up your control positions wherever you like. There are circuit provisions for sync interlocks and for tally lights.

The RCA TS-20 System provides complete master or studio facilities for program monitoring, production talk-back, and video switching between studio camera, film camera, remote pick-up and network programs. For example, you can fade or lap



TELEVISION BROADCAST EQUIPMENT
RADIO CORPORATION of AMERICA
ENGINEERING PRODUCTS DEPARTMENT, CAMDEN, N.J.

In Canada: RCA VICTOR Company Limited, Montreal

3 OF THE MANY ADD-A-UNIT SET-UPS POSSIBLE WITH

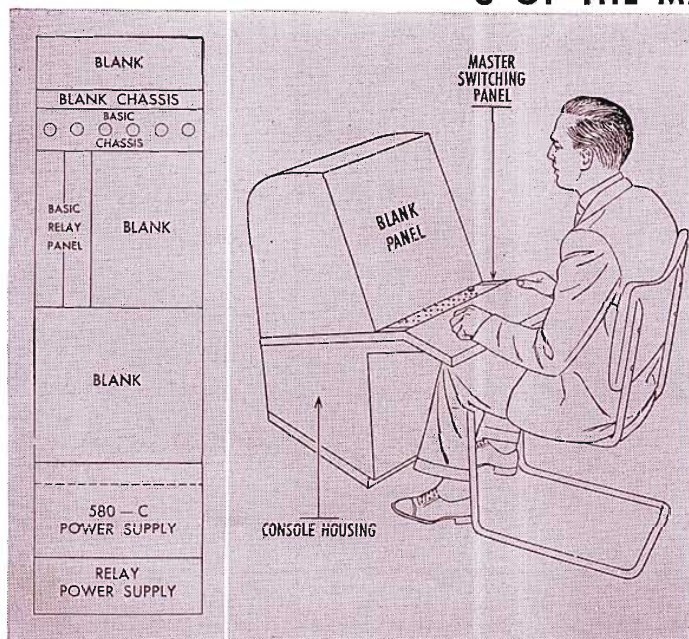

1. Minimum Master Control arrangement. Combines simple operation with economy. Provides switching of 6 inputs to either of 2 outputs.

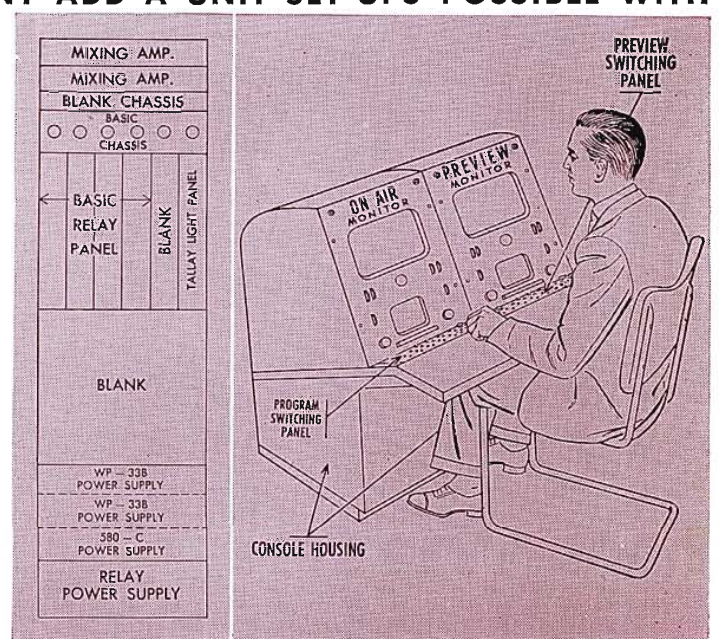

2. Simple Studio Control layout. Additional facilities include: Preview monitoring and line monitoring, fades, lap dissolves, and superimposition.

Switching RELAYS!

For TV master or studio control
one for aural broadcasting.

dissolve between studios. You can set up for program previewing and other monitoring functions (up to 5 program monitors available). You can combine the TS-20A System with audio switching *and* *presetting*, so that the sound switches with the picture *automatically!*

. . .

For long-range planning of your TV programming facilities, overlook none of the advantages of this revolutionary new relay switching system. Ask your RCA Broadcast Sales Engineer about it. Or write Dept. Q-87, RCA Engineering Products, Camden, N. J.

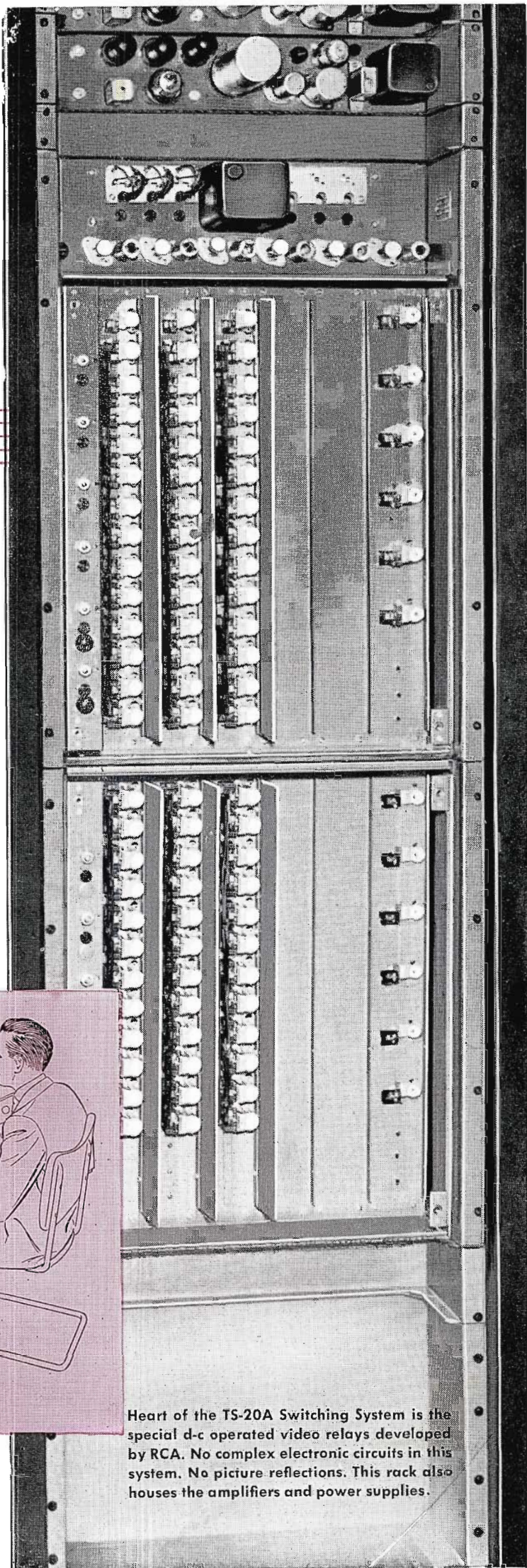

RCA'S TS-20A SYSTEM.

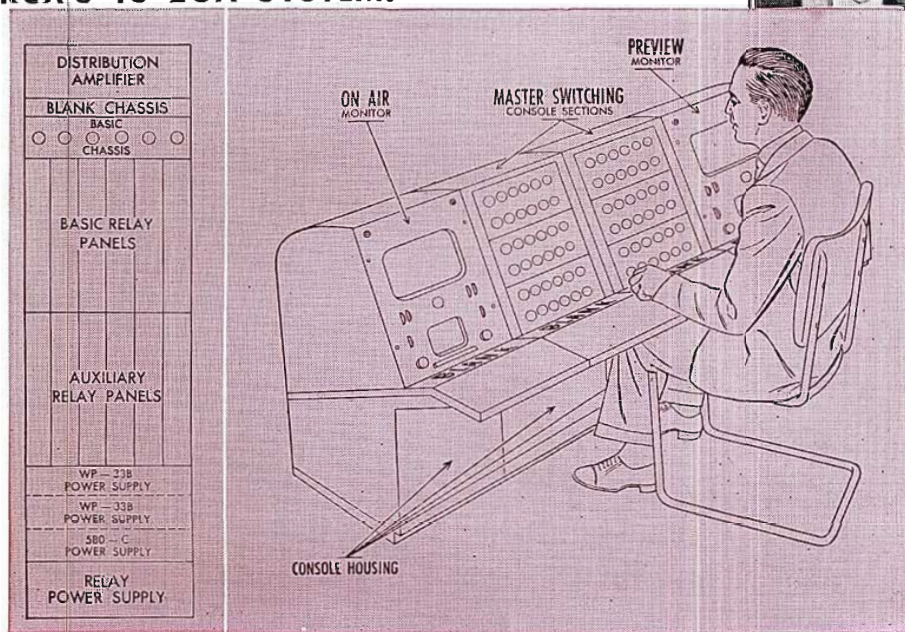

3. A more elaborate master control room set-up than shown in No. 1. Switches any of 12 inputs to any of 5 outgoing lines. Includes preview and line monitoring.

Heart of the TS-20A Switching System is the special d-c operated video relays developed by RCA. No complex electronic circuits in this system. No picture reflections. This rack also houses the amplifiers and power supplies.

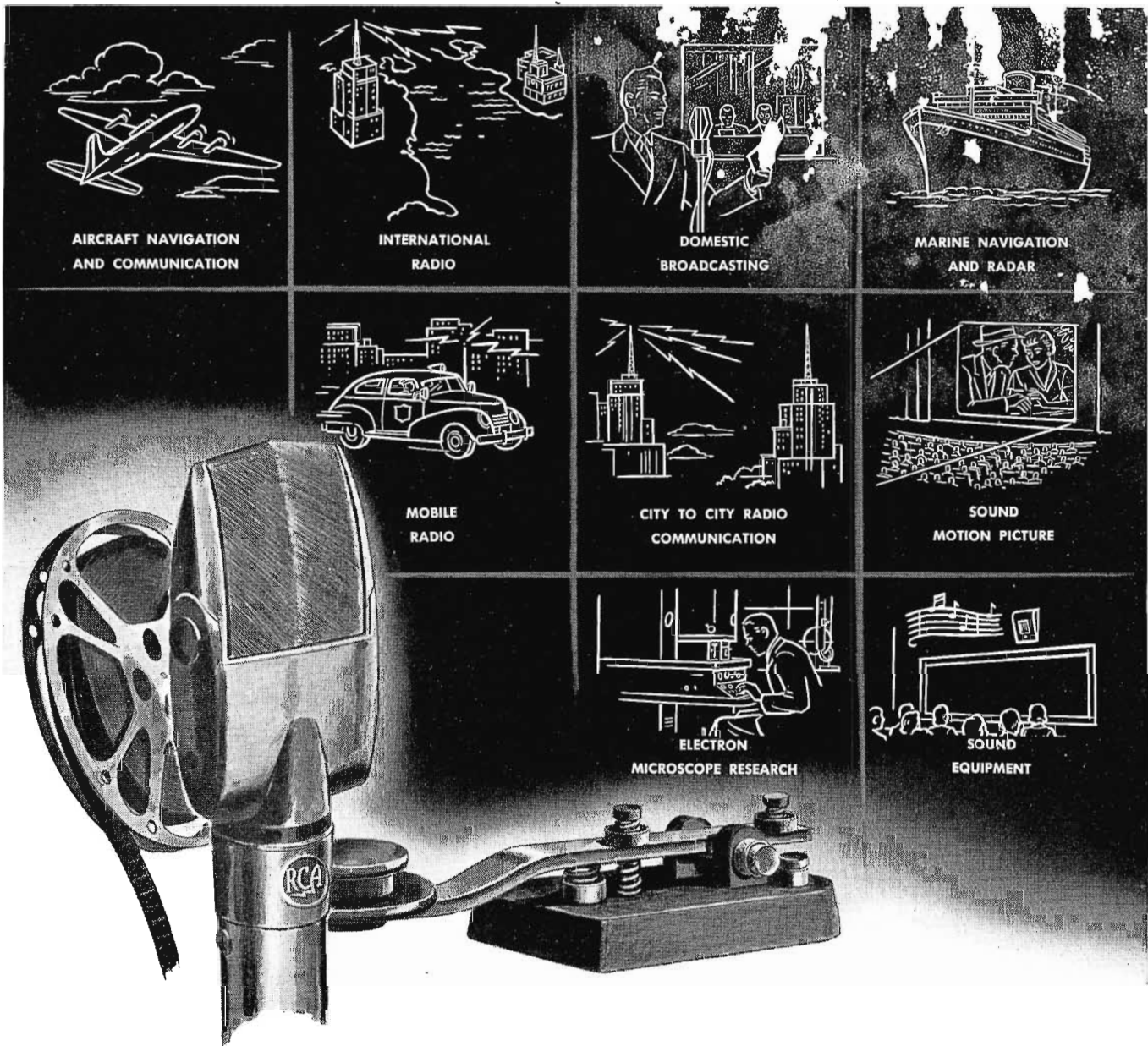

The tools of modern government

Modern nations maintain their world position today with the tools of radio and electronics.

International—The volume of present-day communications on a global scale... the precision of aerial and marine navigation... the ordered conduct of business... the proper statement of government policies to the world... all are dependent upon reliable radio communications equipment.

Domestic—Wise government is aware

of the educational and cultural advantages of the radio broadcast and the documentary sound motion picture... and of the unifying influence these voices exert upon their citizens. Government is also broadening its use of radio-equipped vehicles in municipal police, fire and health services.

Public Welfare—Still another tool, the Electron Microscope, affords amazing penetration into the fundamental causes of disease, the structure

and properties of materials, the uncovering of new products and processes... important contributions to better health and economic advancement.

RCA has all of these tools of modern government. You are cordially invited to contact the RCA distributor in your area for information on this equipment. You will find his long experience of practical value. Or write direct to RCA, International Division.



RCA INTERNATIONAL DIVISION

RADIO CORPORATION of AMERICA

RCA BUILDING

30 ROCKEFELLER PLAZA, NEW YORK, N.Y., U.S.A.



All new

RCA Limiting Amplifier BA-6A

For high-fidelity AM and FM speech input systems

FEATURES

- No matched tubes required
- Choice of single or dual time constant
- Greater reliability—push-pull stages throughout
- High gain—Low noise level
- Adjustable T-pad in output
- Standard plug-in mounting—for new handling convenience

SPECIFICATIONS

- Output level at verge of limiting, 30 dbm
- Gain, 54 db
- Noise level—down 83 db at verge of limiting
- Frequency response ± 1 db, 30-15,000 cycles
- Distortion (12 db gain reduction), 1%
- Takes only $8\frac{3}{4}$ inches of rack space. Weighs only 37 pounds.

This represents the ultimate in useful performance... at lower cost

Save yourself hundreds of dollars when you buy your limiting amplifier. Specify a BA-6A. For complete details, call your RCA Broadcast Sales Engineer. Or write Dept. PA-19, RCA Engineering Products, Camden, N. J.



AUDIO BROADCAST EQUIPMENT
RADIO CORPORATION of AMERICA
ENGINEERING PRODUCTS DEPARTMENT, CAMDEN, N. J.

In Canada: RCA VICTOR Company Limited, Montreal.



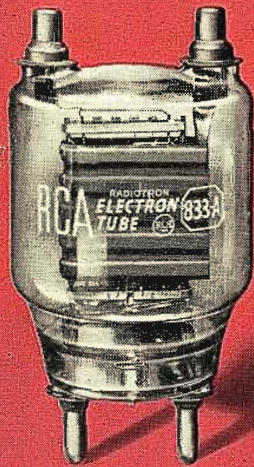
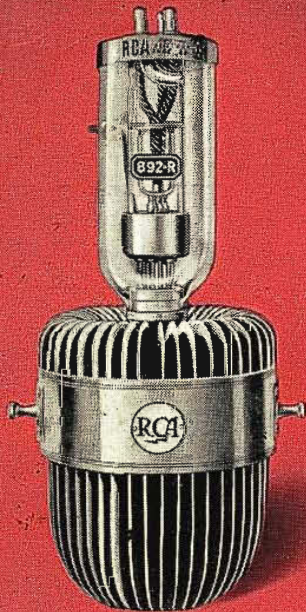

FAITHFUL SERVANTS of AM Broadcasting

BY FAITHFULLY SERVING the important requirements of AM broadcasting, RCA tubes have won an unqualified reputation for engineering excellence, dependability, and true operating economy.

In the future, as in the past, AM broadcasters can look to RCA for the finest in power tubes. RCA consistently follows a program of developing new AM tube types and of improving earlier AM types. *For example:*

RCA 892-R—The forerunner of a group of RCA-designed air-cooled power amplifier tubes that simplified transmitter construction and introduced new operating and maintenance economies. Today, hundreds of these tubes are demonstrating their long life and dependability in the nation's leading 5- and 50-kw AM transmitters.

RCA 833-A—Originally designed by RCA engineers, this power triode features a giant zirconium-coated anode for greater dissipation, shielding that eliminates bulb bombardment, and a husky filament that has tremendous emission reserve for peak loads. These features have contributed to more dependable operation, longer service life, and greater operating economy.

RCA 5671—A recent addition to the RCA line, this power triode with its *thoriated-tungsten filament* draws 60 per cent less filament power than the previous pure-tungsten-filament type . . . making possible a saving of \$1200 or more a year in filament power in standard 50-kw AM transmitters. *Performance-proved* in the field.

✓ **A REMINDER**—RCA tubes for all types of broadcast service are available from your local RCA Tube Distributor or direct from RCA.



RCA LABORATORIES

PRINCETON, N. J.

THE FOUNTAINHEAD OF MODERN TUBE DEVELOPMENT IS RCA



RADIO CORPORATION of AMERICA
ELECTRON TUBES

HARRISON, N. J.